



<https://t.me/learningnets>



PROJECT

ENG

PRO

CYBER SECURITY FOR INDUSTRIAL CONTROL SYSTEMS

By Project **ENG PRO**



Distributed Control Systems Introduction

DCS



What is a DCS?

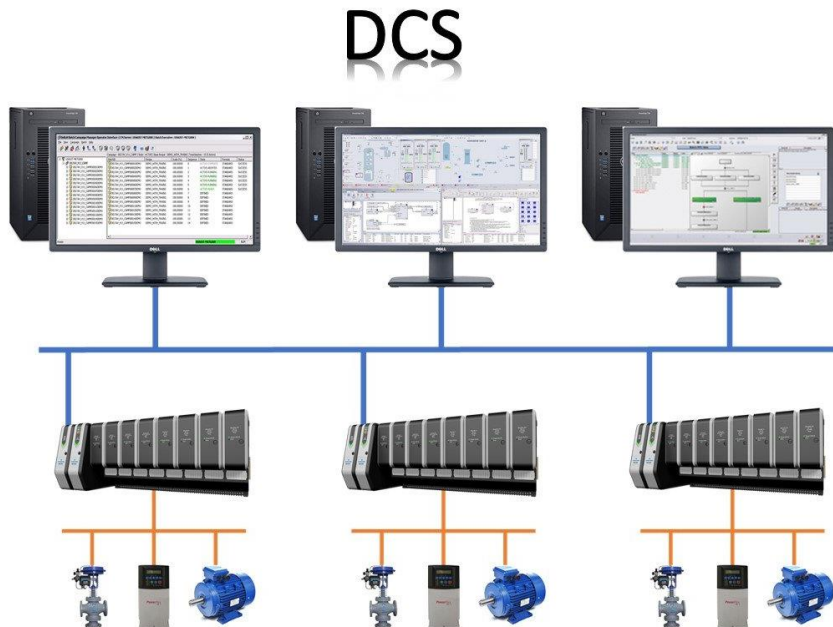

DCS refers to a control system where the control functions are distributed rather than centralized on a single controller or algorithm. This distributed nature allows for the placement of multiple controllers and automation systems across a large geographical area, which in turn enables centralized monitoring and control from a single console or operator workstation.

A large industrial facility at night, featuring complex piping, scaffolding, and a central cylindrical structure. Two workers in blue uniforms are visible in the foreground. The scene is dimly lit, with some lights illuminating the structures.

Applications

- Oil and Gas
- Energy Utilities
- Chemical Plants
- Manufacturing Plants
- Pharmaceuticals

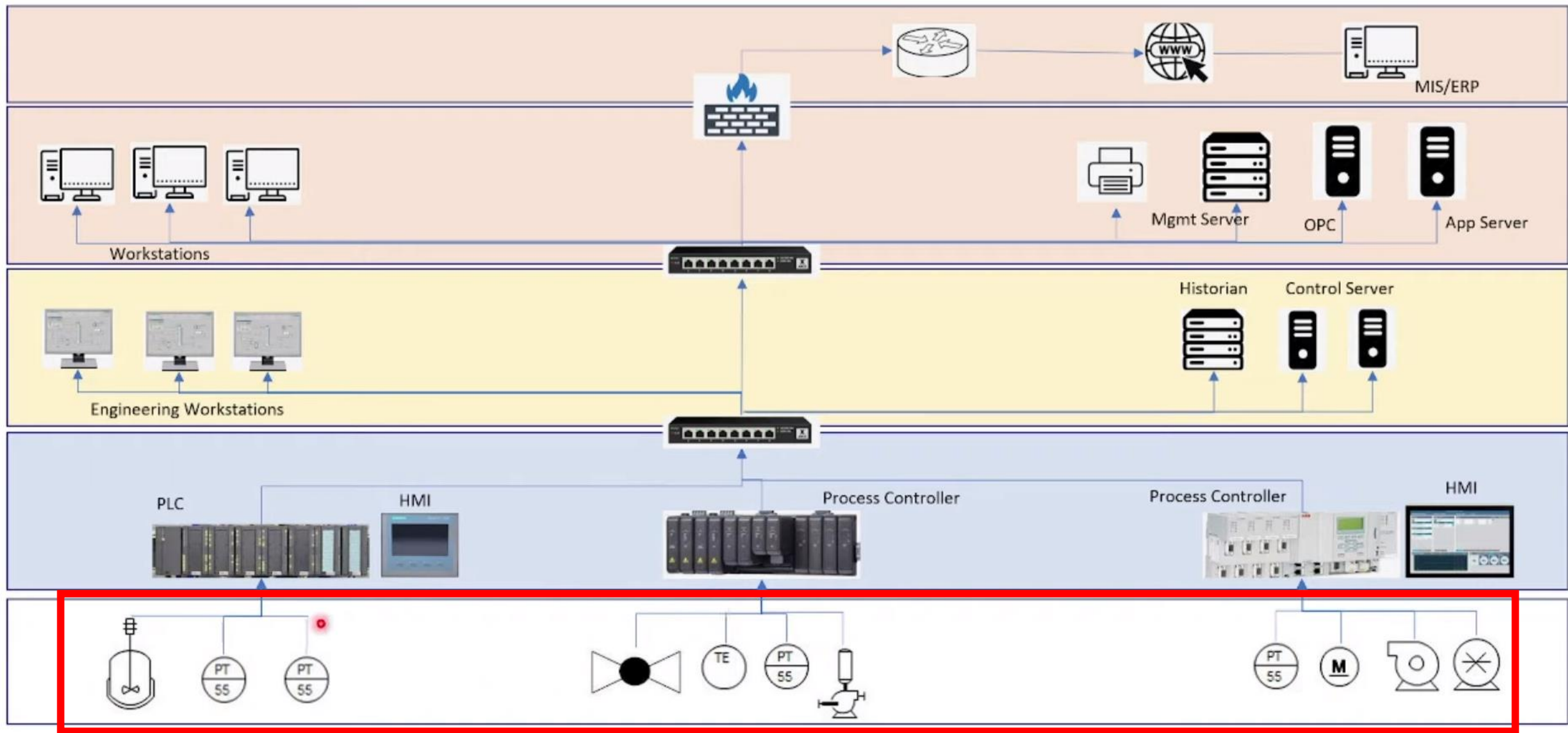

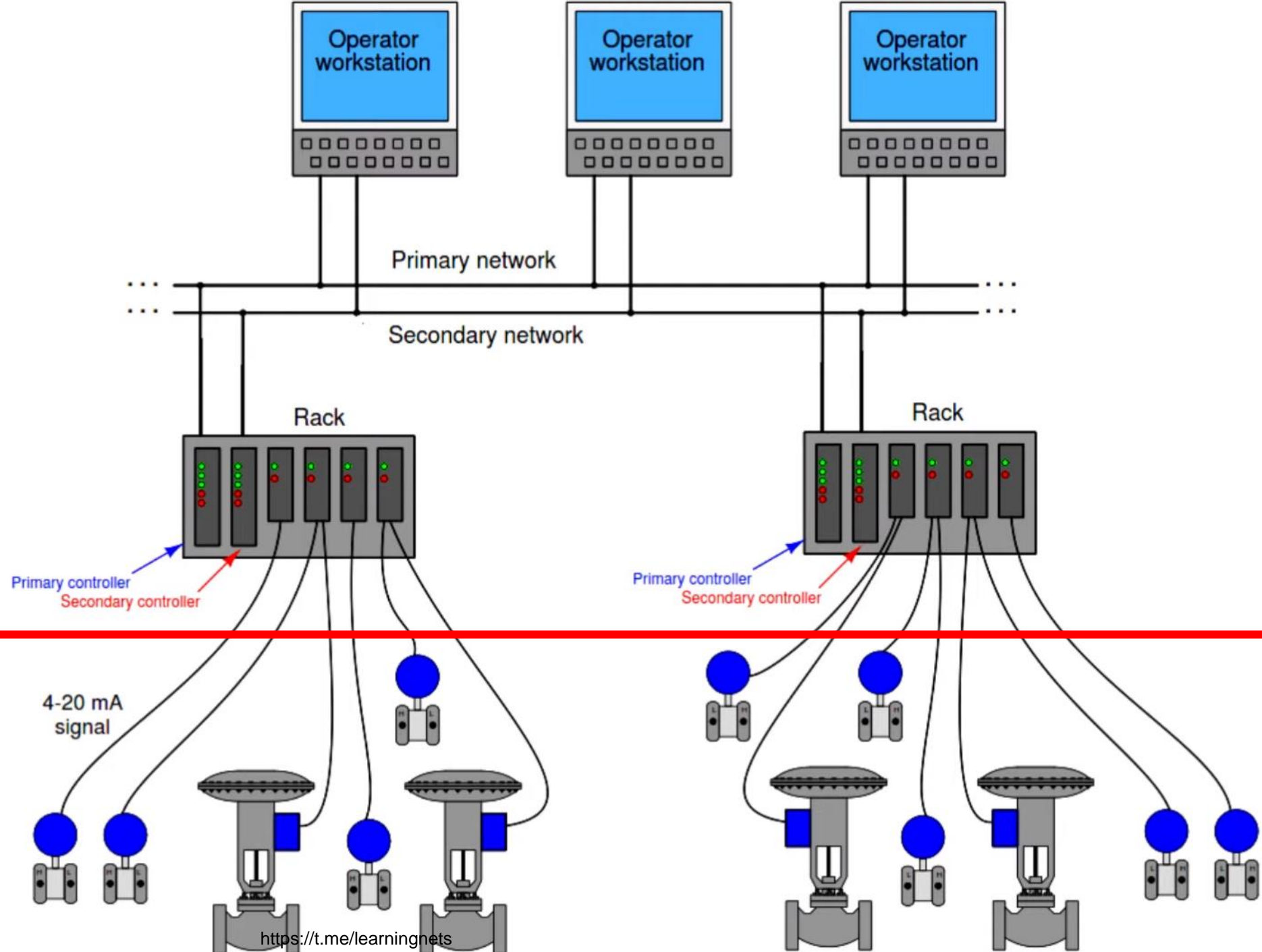

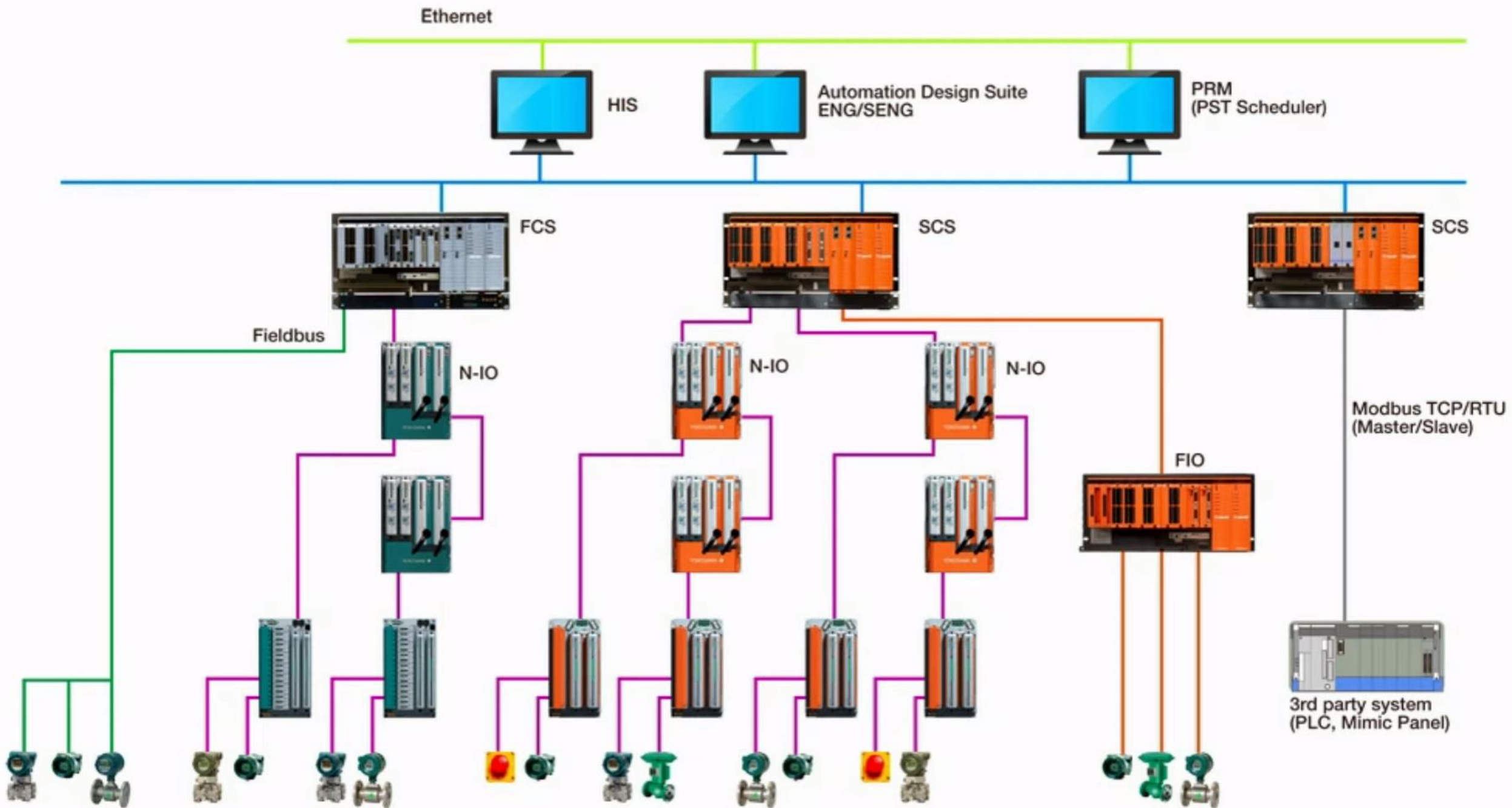

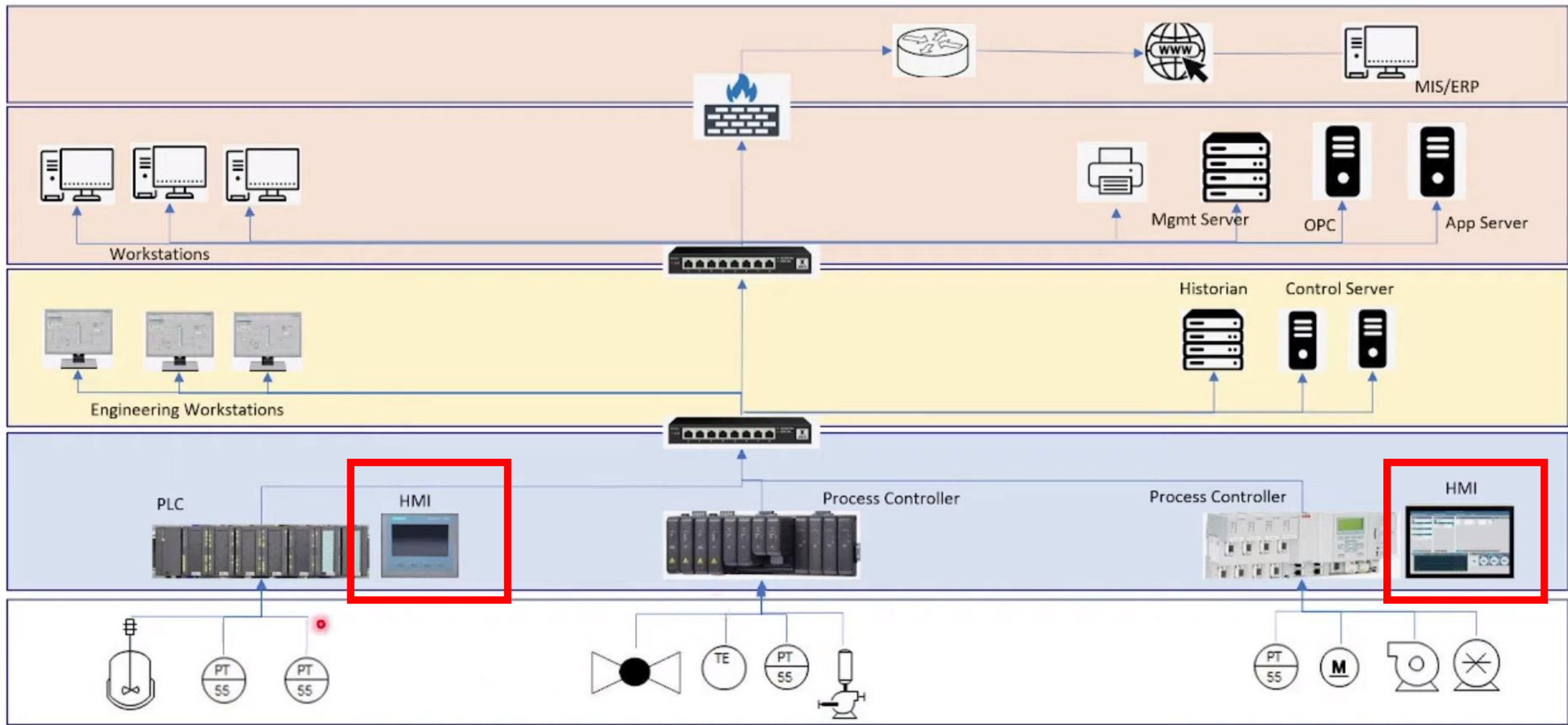

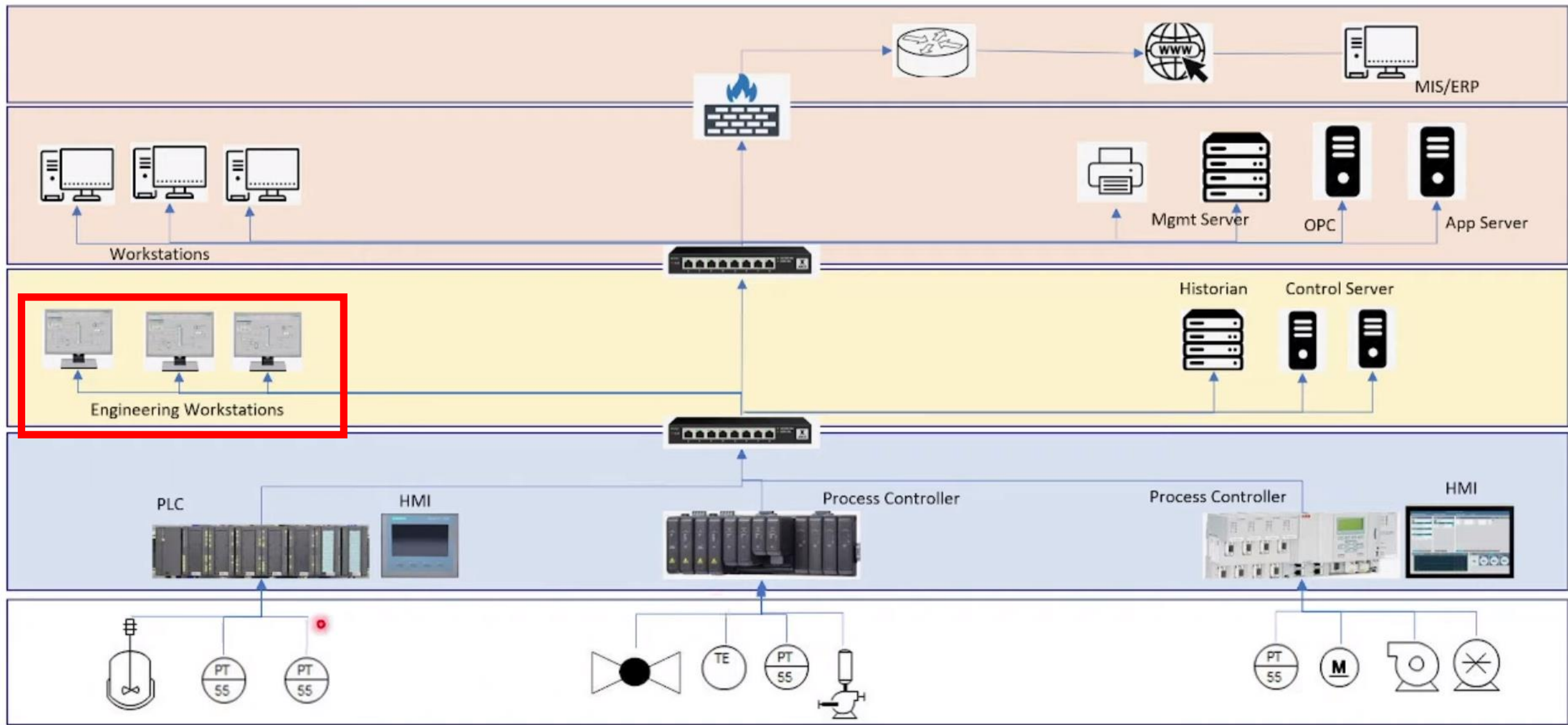

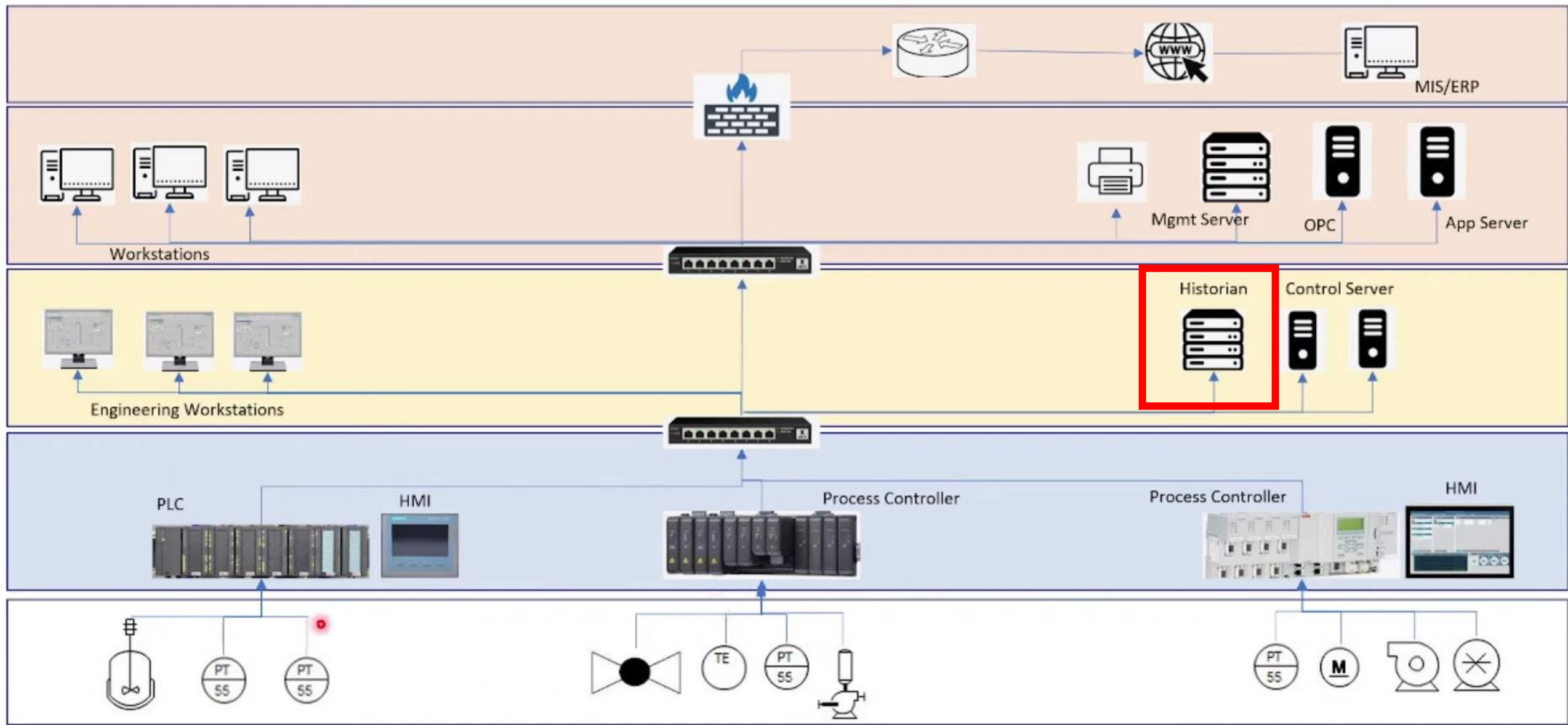

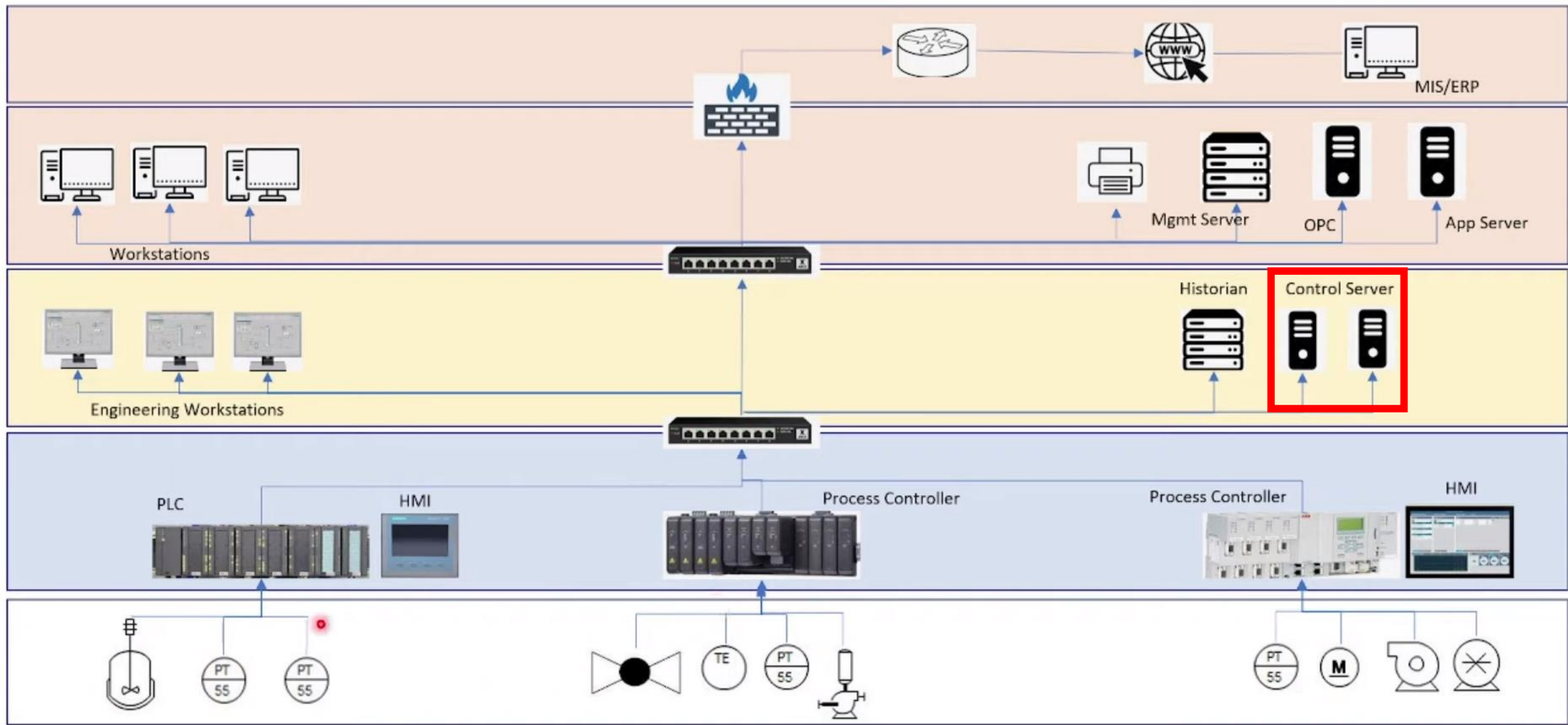

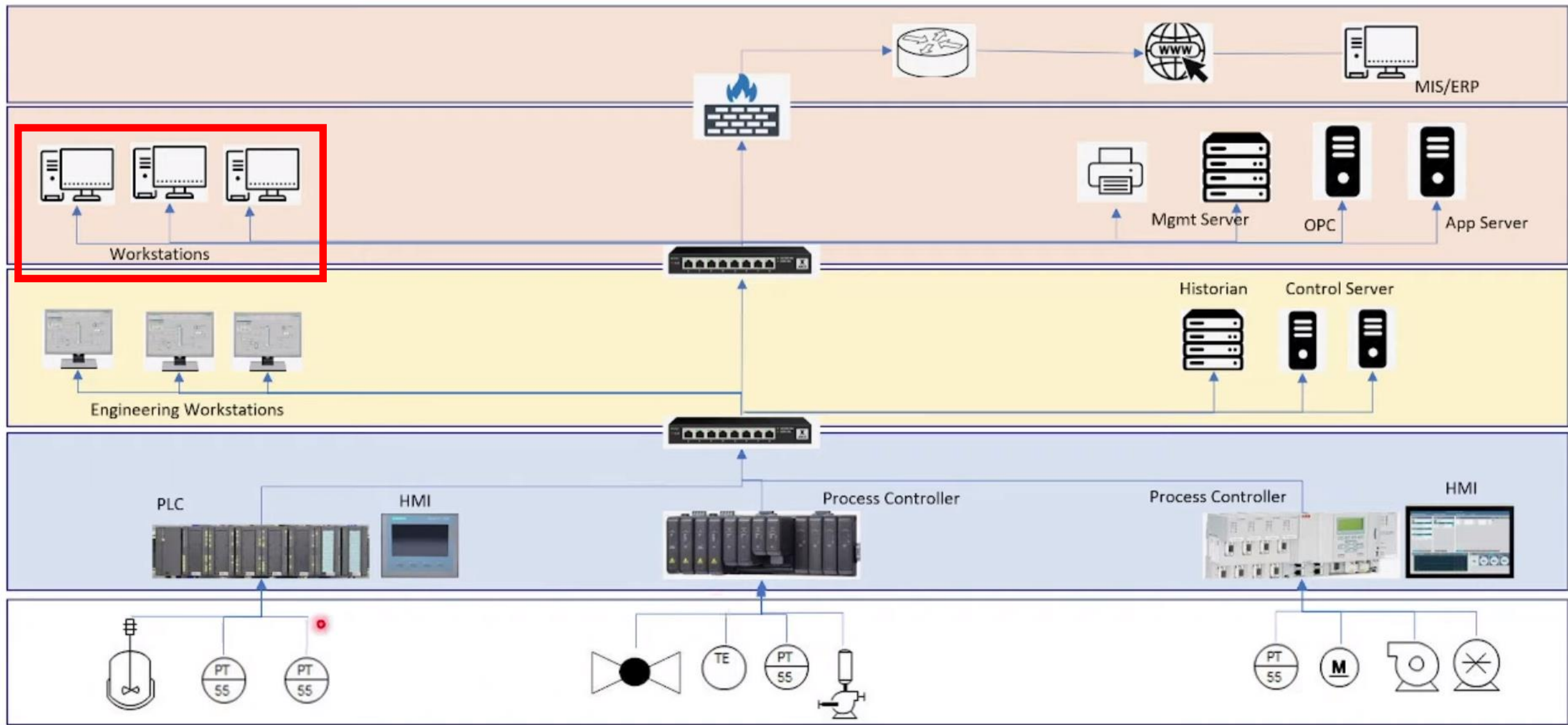

Communication Protocols

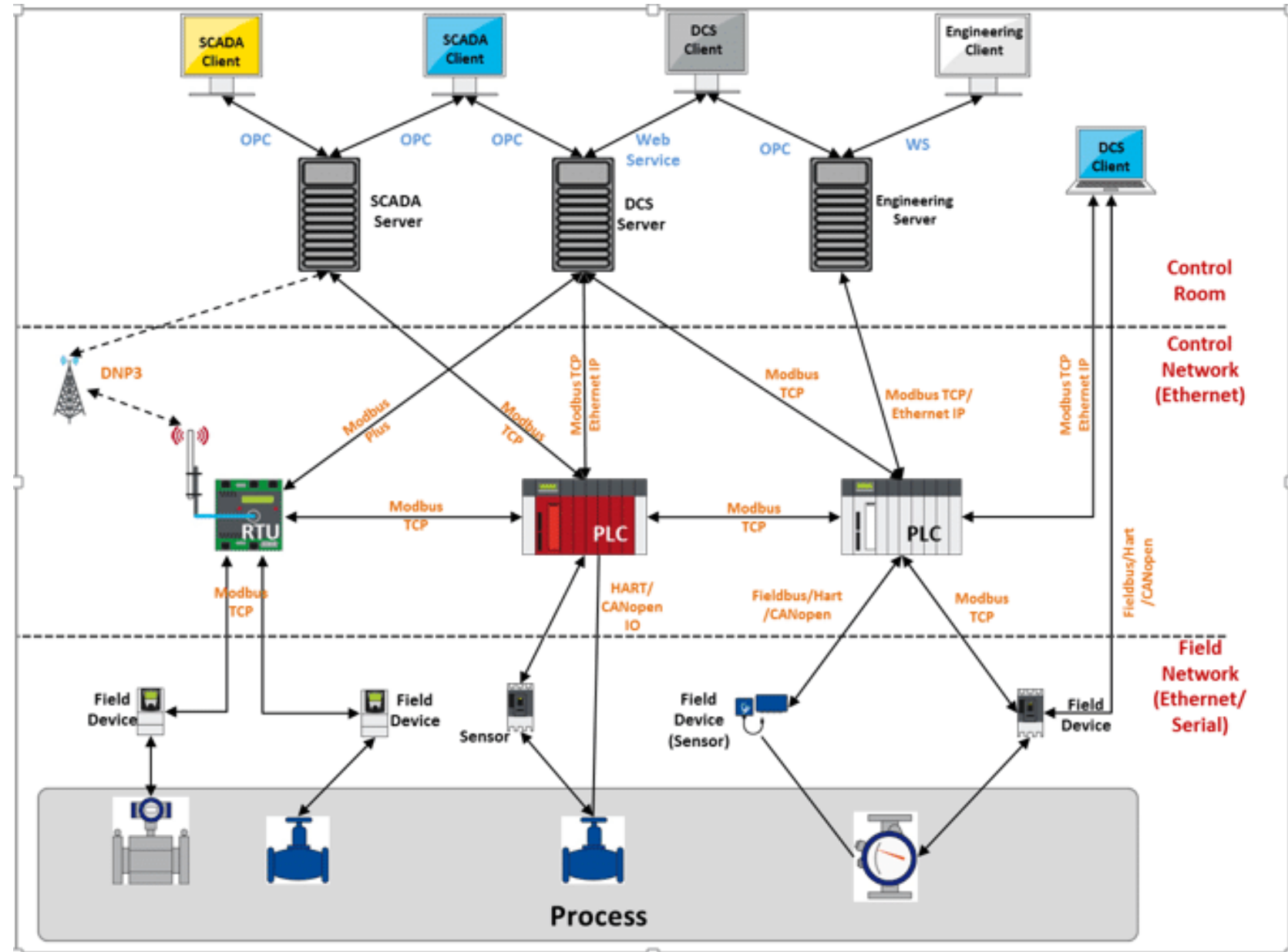

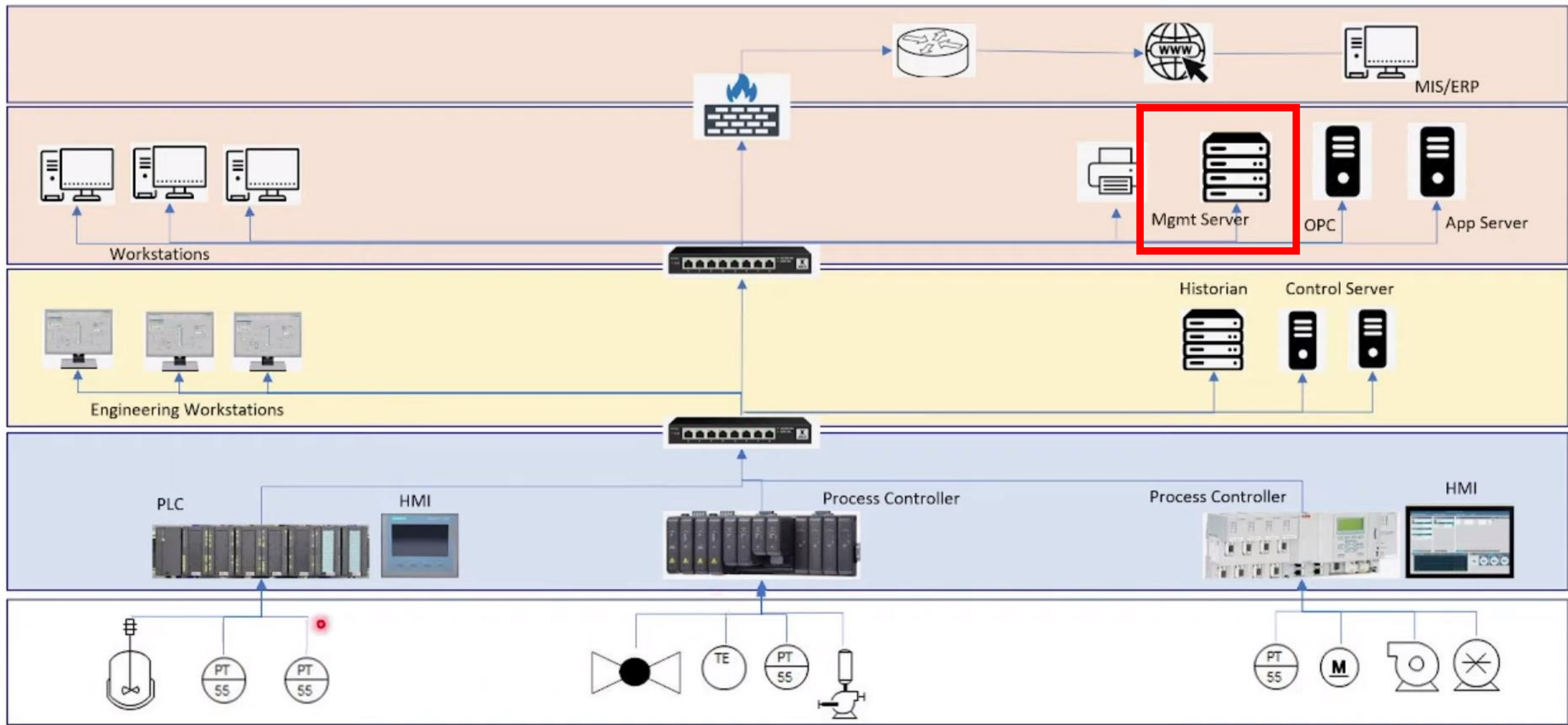

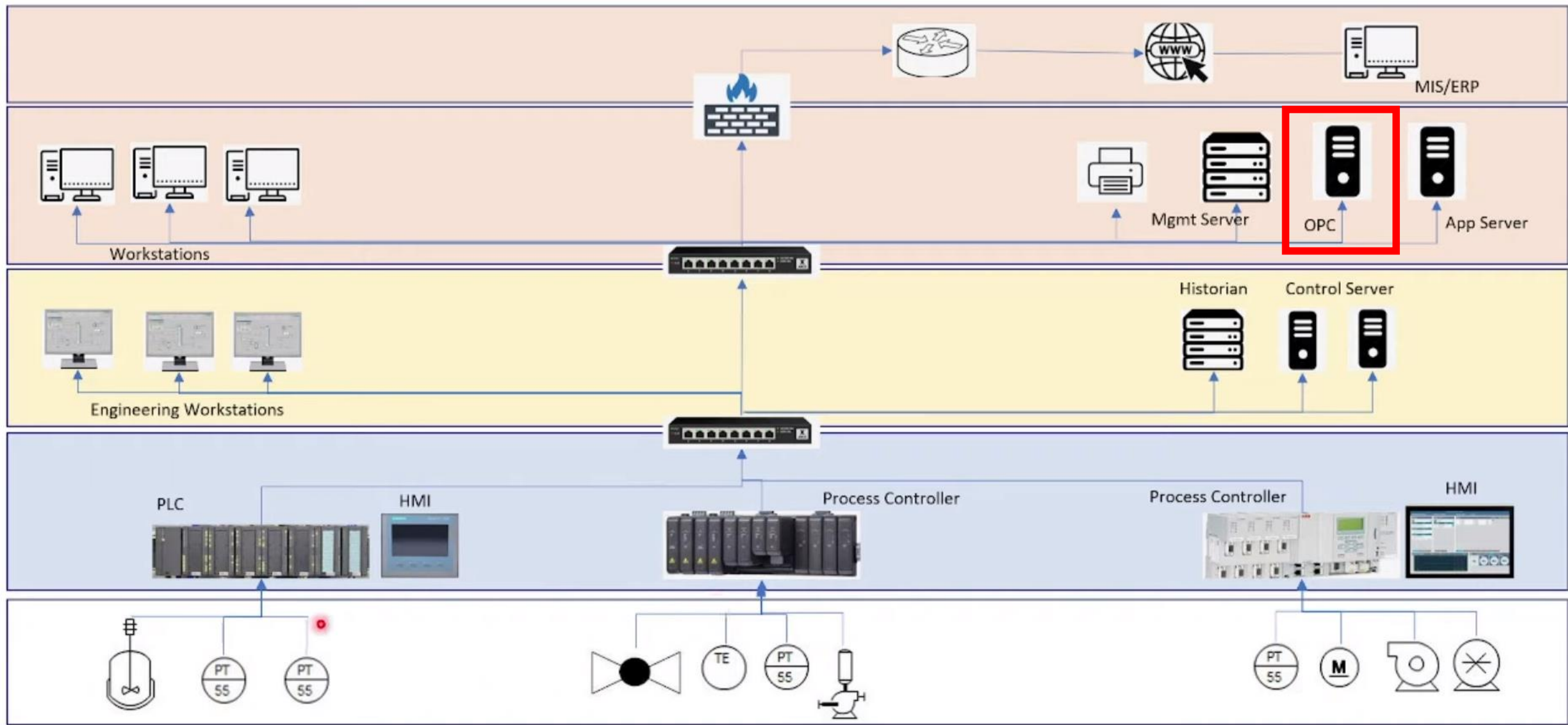

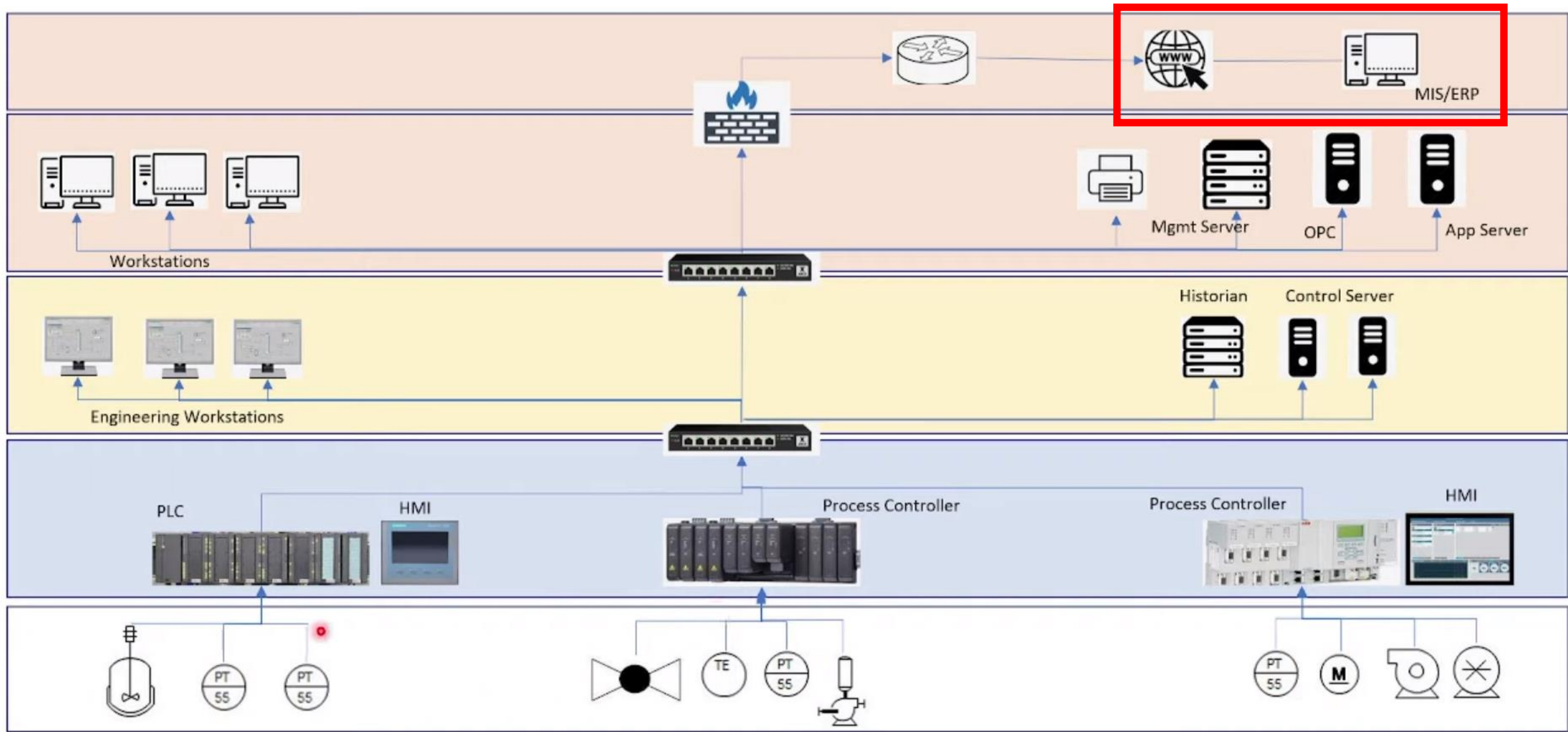

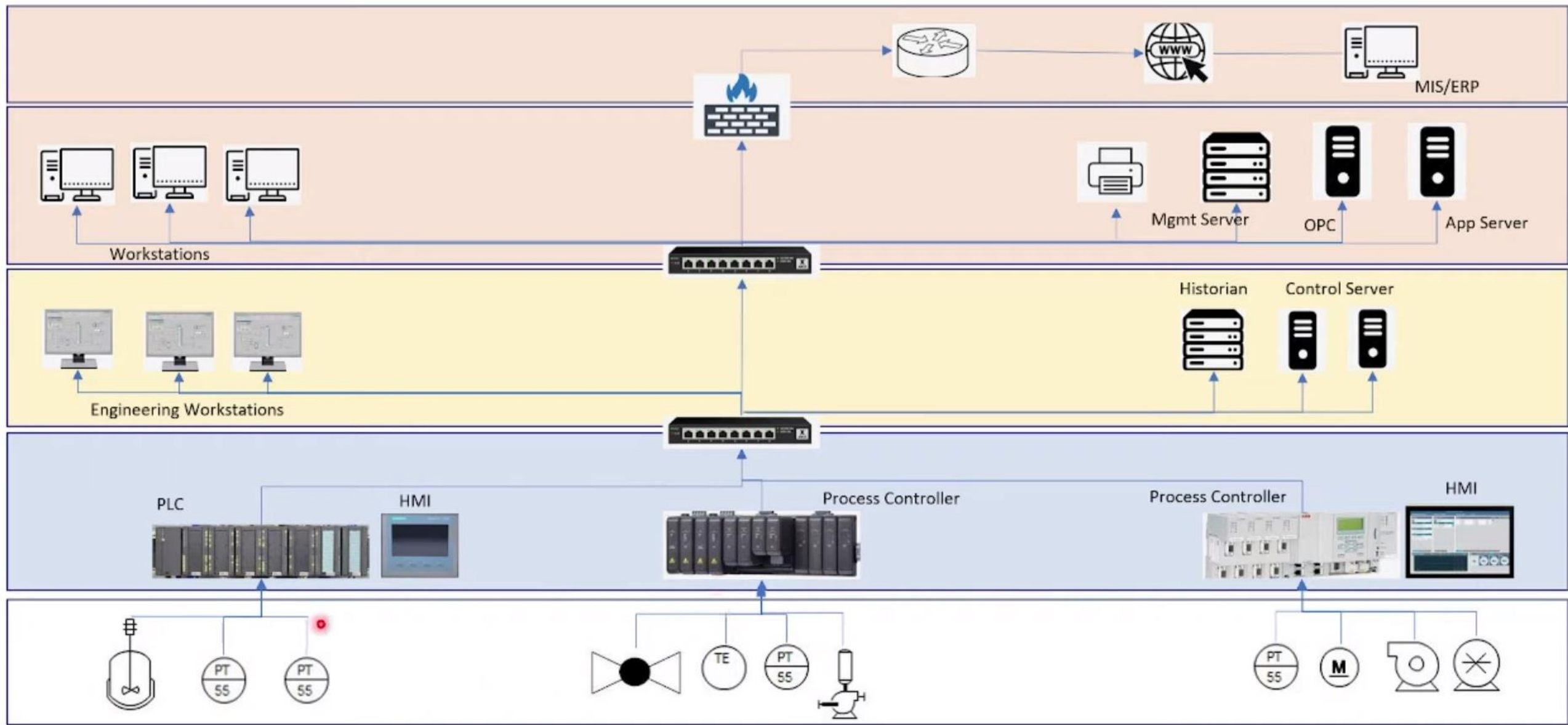

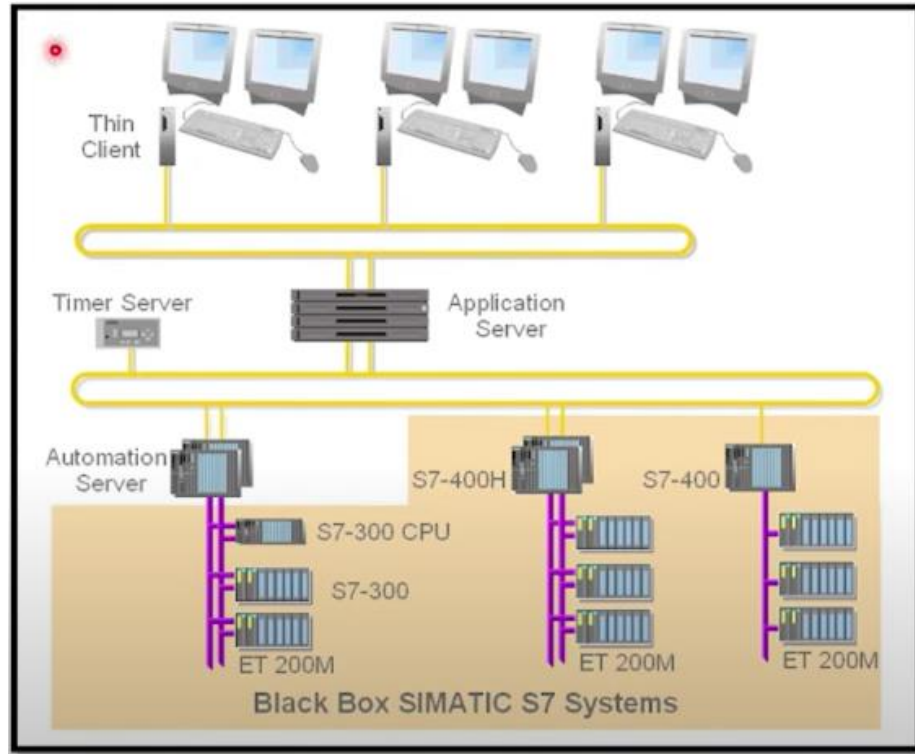

SPPA-T3000 Architecture

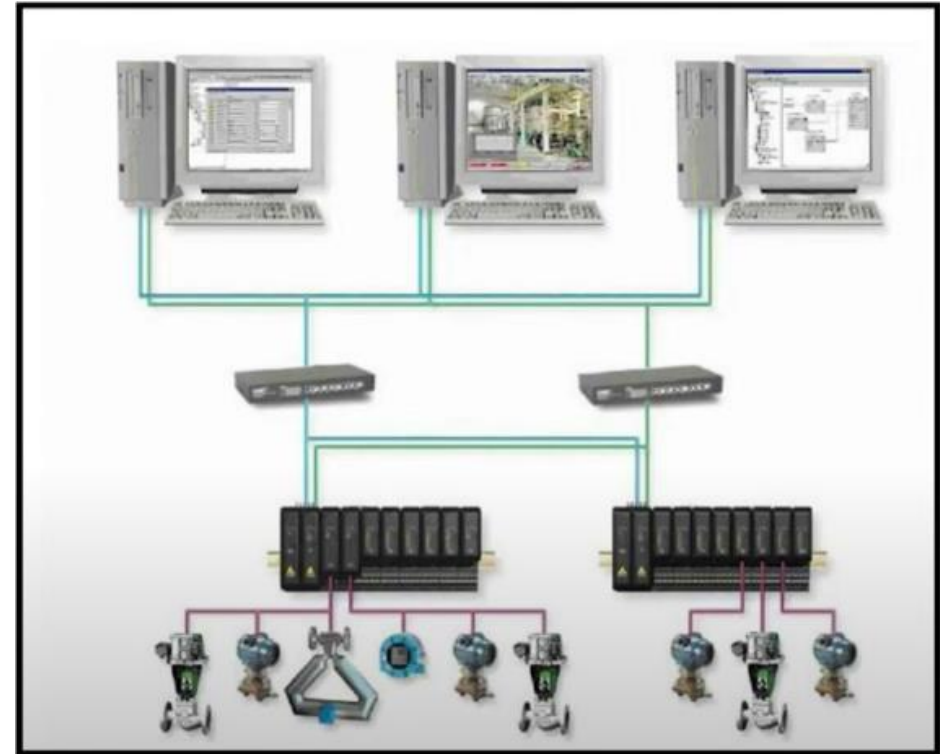

Delta V Architecture

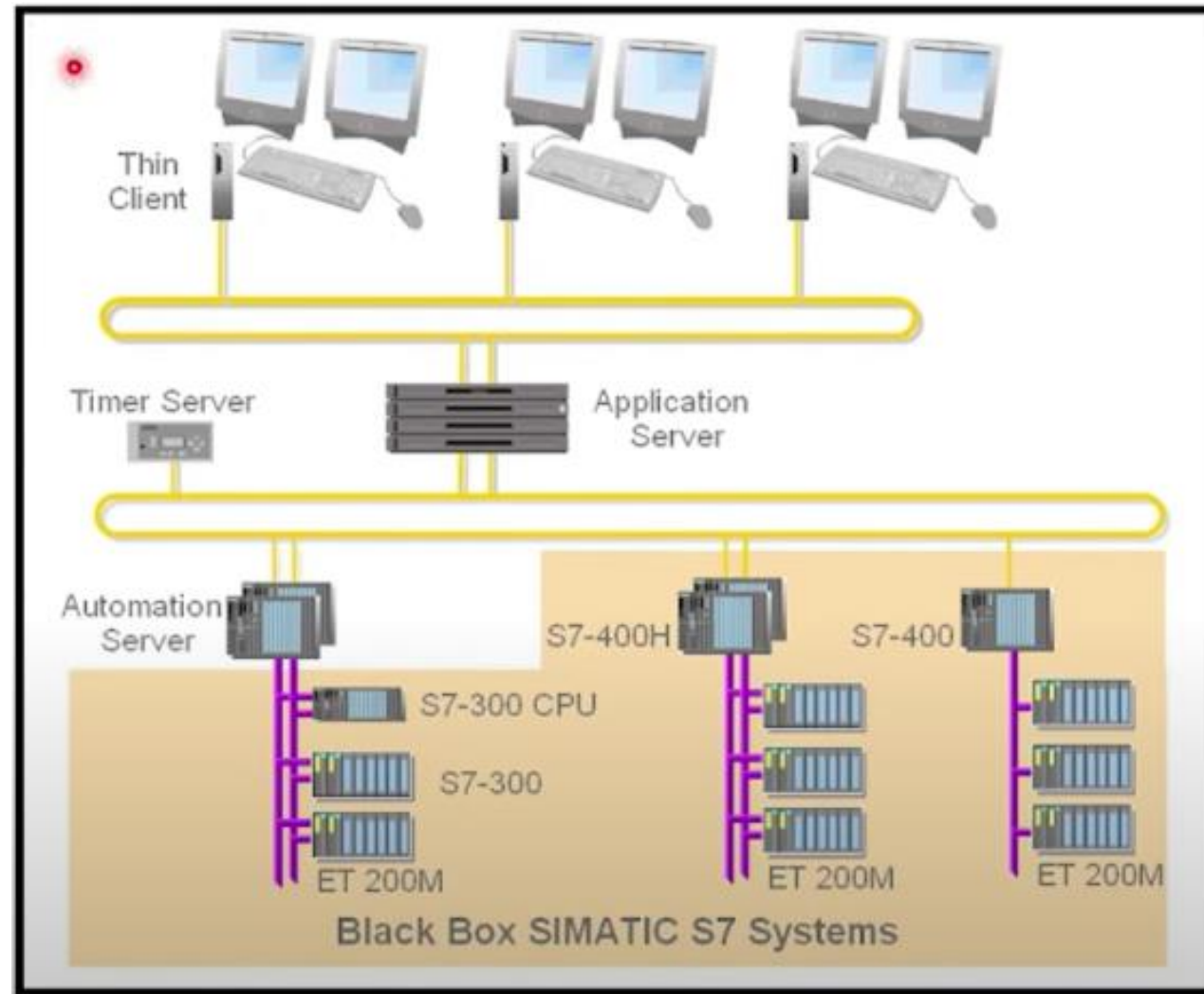

SPPA-T3000 Architecture

Delta V Architecture

DeltaV Architecture: In this DCS setup, we observe a similar structure as in the previous example. Field automation is facilitated through DeltaV I/O cards, which gather data from sensors and devices in the field. These cards feed data into controllers, forming the foundation of control logic.

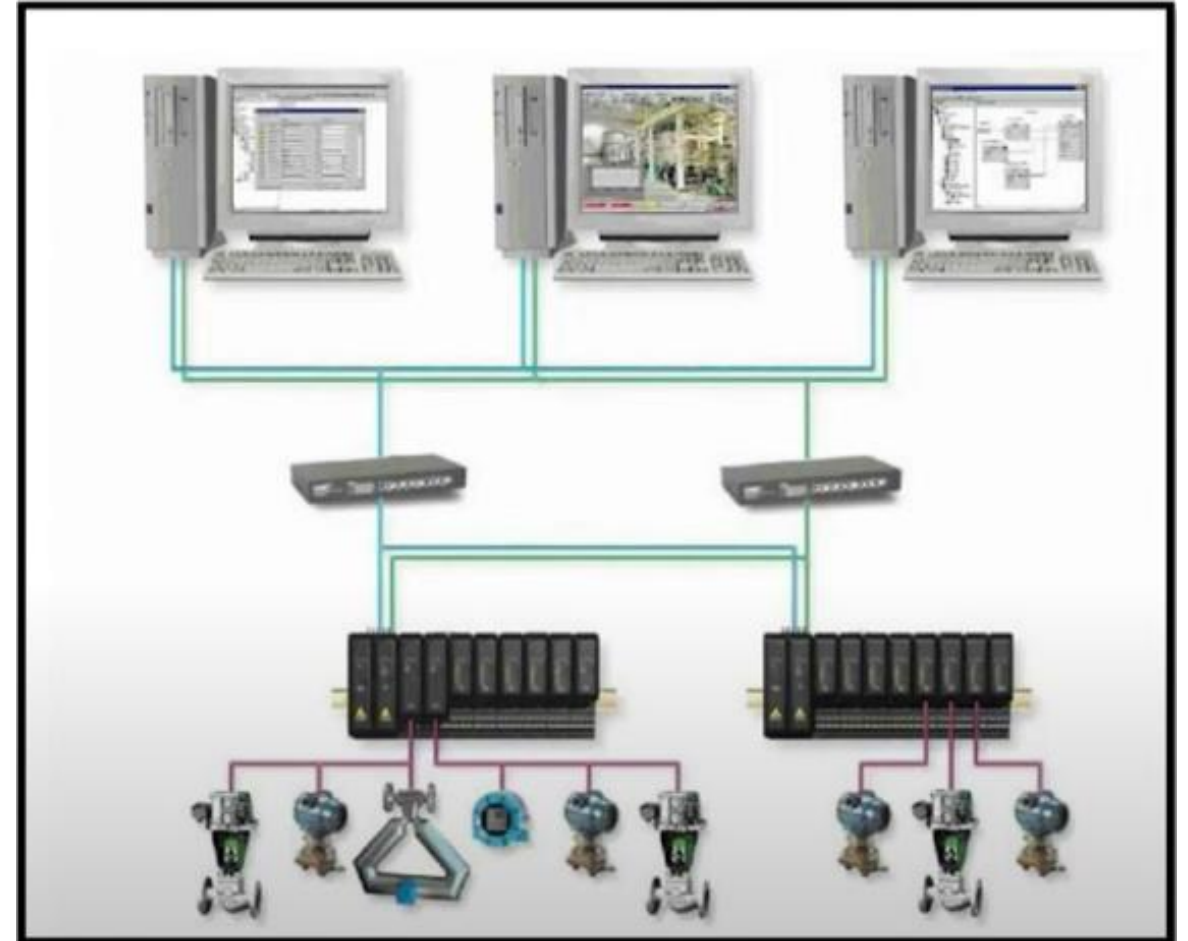

Wrap Up

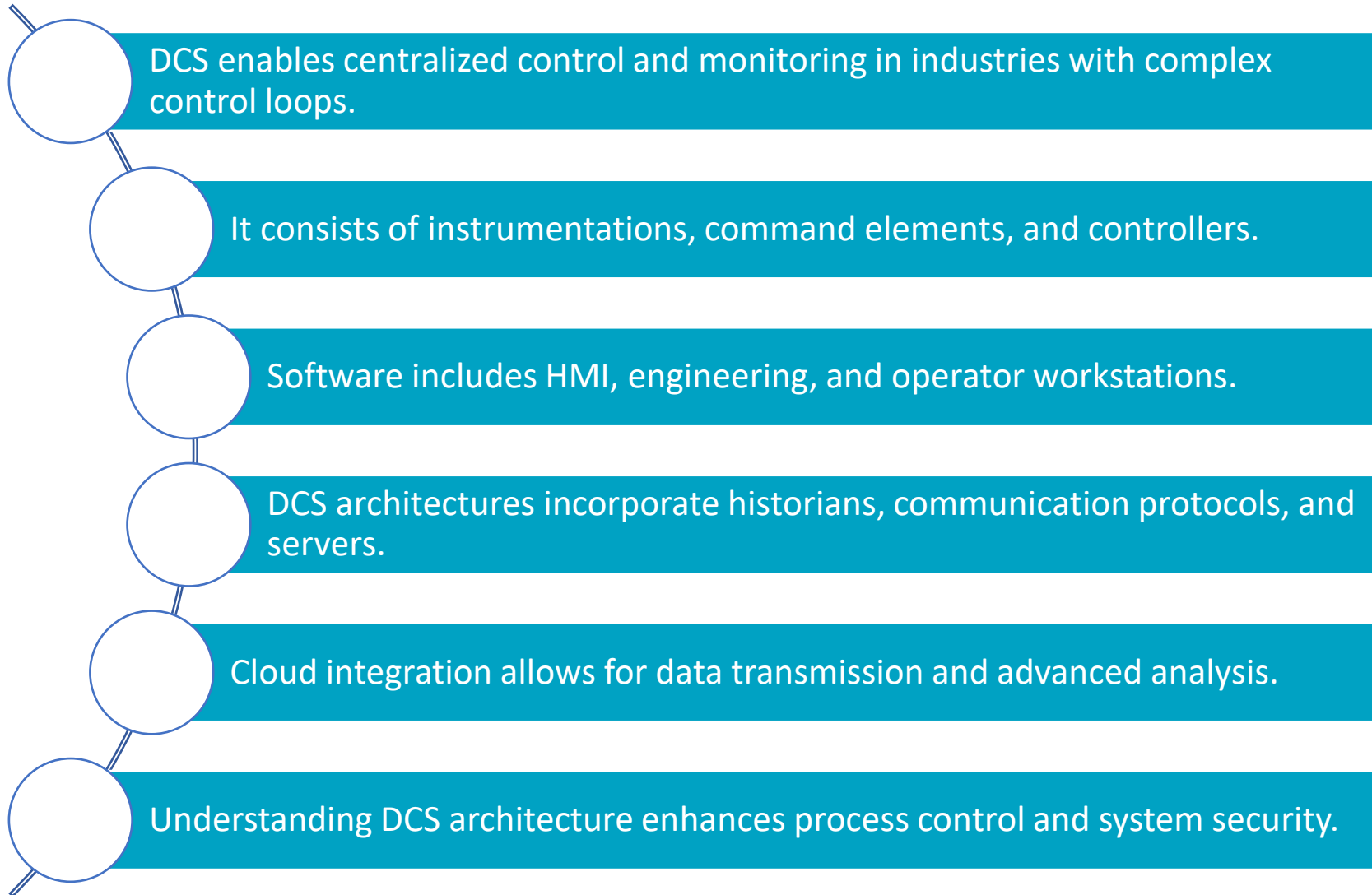



<https://t.me/learningnets>