



DATA-ONLY ATTACKS AGAINST UEFI BIOS

Alexander Ermolov

#whoami



- Intel Management Engine
 - [Intel AMT. Stealth Breakthrough](#)
- Intel Boot Guard
 - [Safeguarding rootkits: Intel Boot Guard](#)
 - [Bypassing Intel Boot Guard](#)
- UEFI BIOS
 - [UEFI BIOS holes. So Much Magic, Don't Come Inside](#)
 - [NUClear explotion](#)
 - [Microcode downgrade](#)
 - [Untrusted Roots: Exploiting vulnerabilities in Intel ACMs](#)

#agenda

- UEFI BIOS Security
- SMM Mitigations
- Is that enough?
- Vulns
- NVRAM stories

UEFI BIOS SECURITY

UEFI BIOS common security

BIOS Lock Enable (BLE)

If BLE = 1, any attempt to set BIOS WE = 1 (required before starting flash operation cycles in SPIBAR) will trigger hardware SMI handler to set BIOS WE = 0.

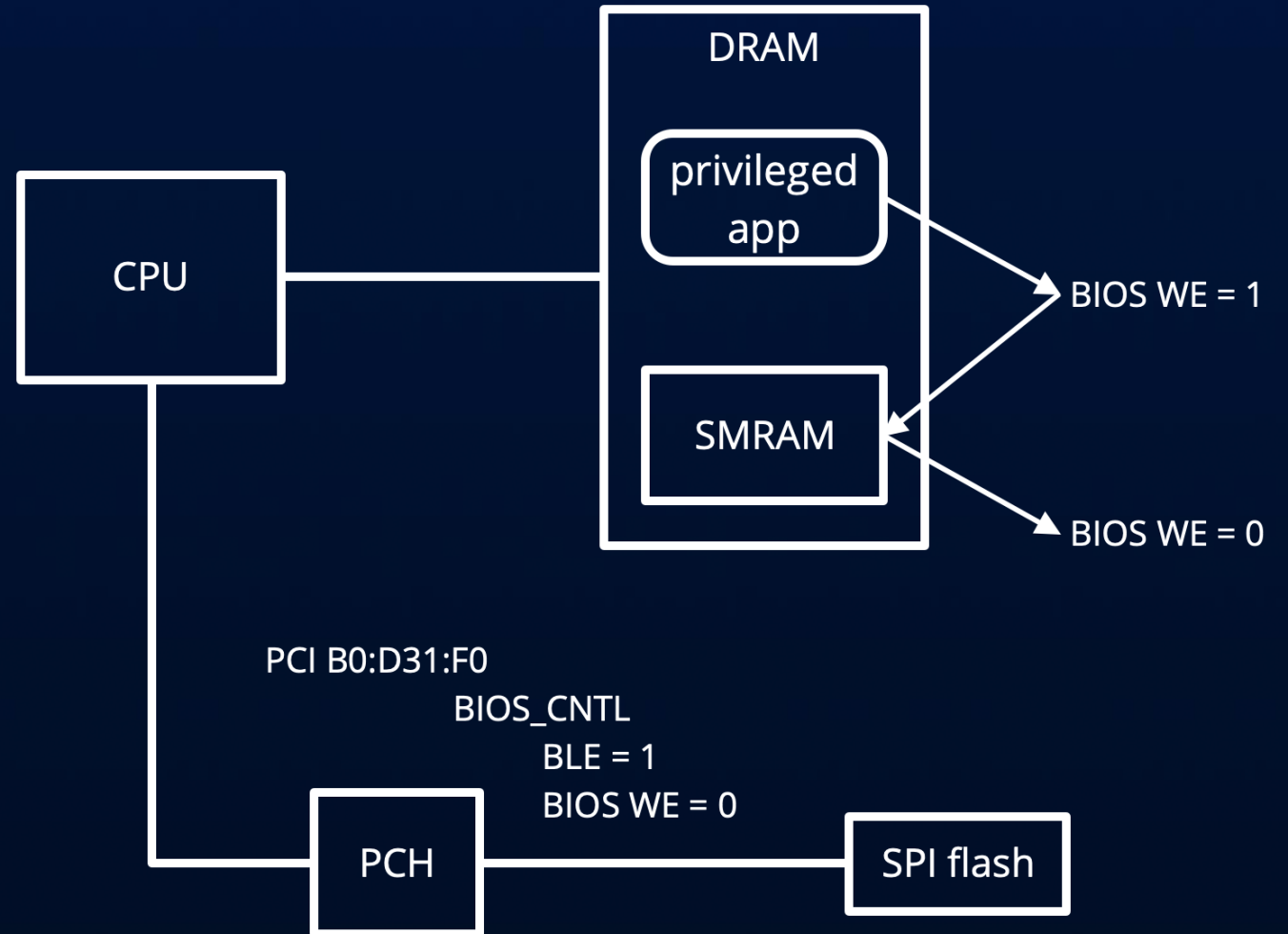

[OpenSecurityTraining by Xeno Kovah & Corey Kallenberg, LegbaCore LLC](#)

BTW check this out! [OpenSecurityTraining2 by Xeno Kovah](#)

UEFI BIOS common security

BIOS Lock Enable (BLE)

On multicore systems this protection is vulnerable to a race condition attack (aka Speed Racer).

While one CPU Core is in SMM and the other still not, there is a small time window to write to BIOS region before it will be switched to SMM.

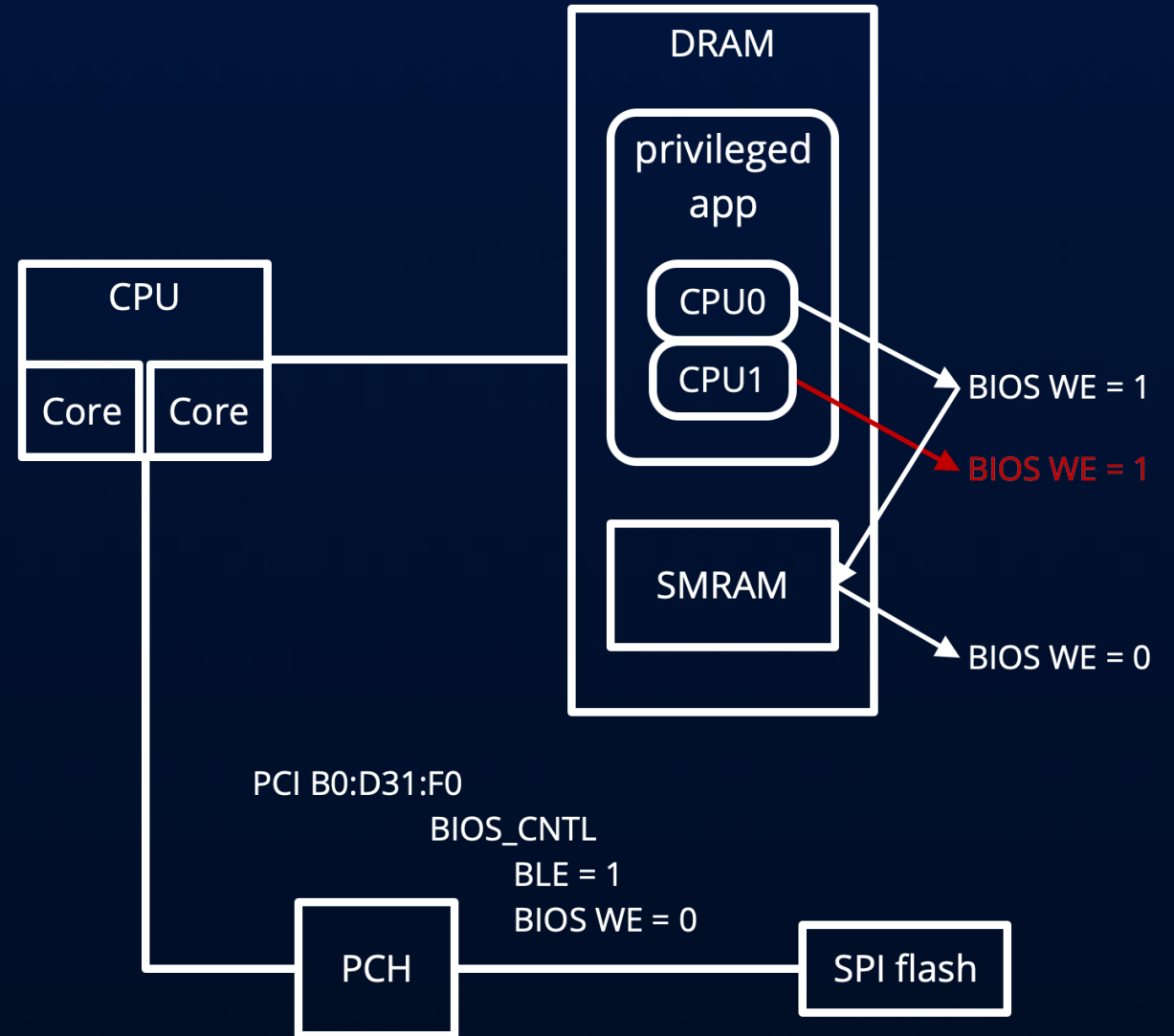

<https://t.me/learningnets> Speed Racer: Exploiting an Intel Flash Protection Race Condition by Corey Kallenberg & Rafal Wojtczuk

UEFI BIOS common security

SMM BIOS Write Protect (SMM_BWP)

If SMM_BWP = 1, BIOS is not writable unless all processors are in SMM.

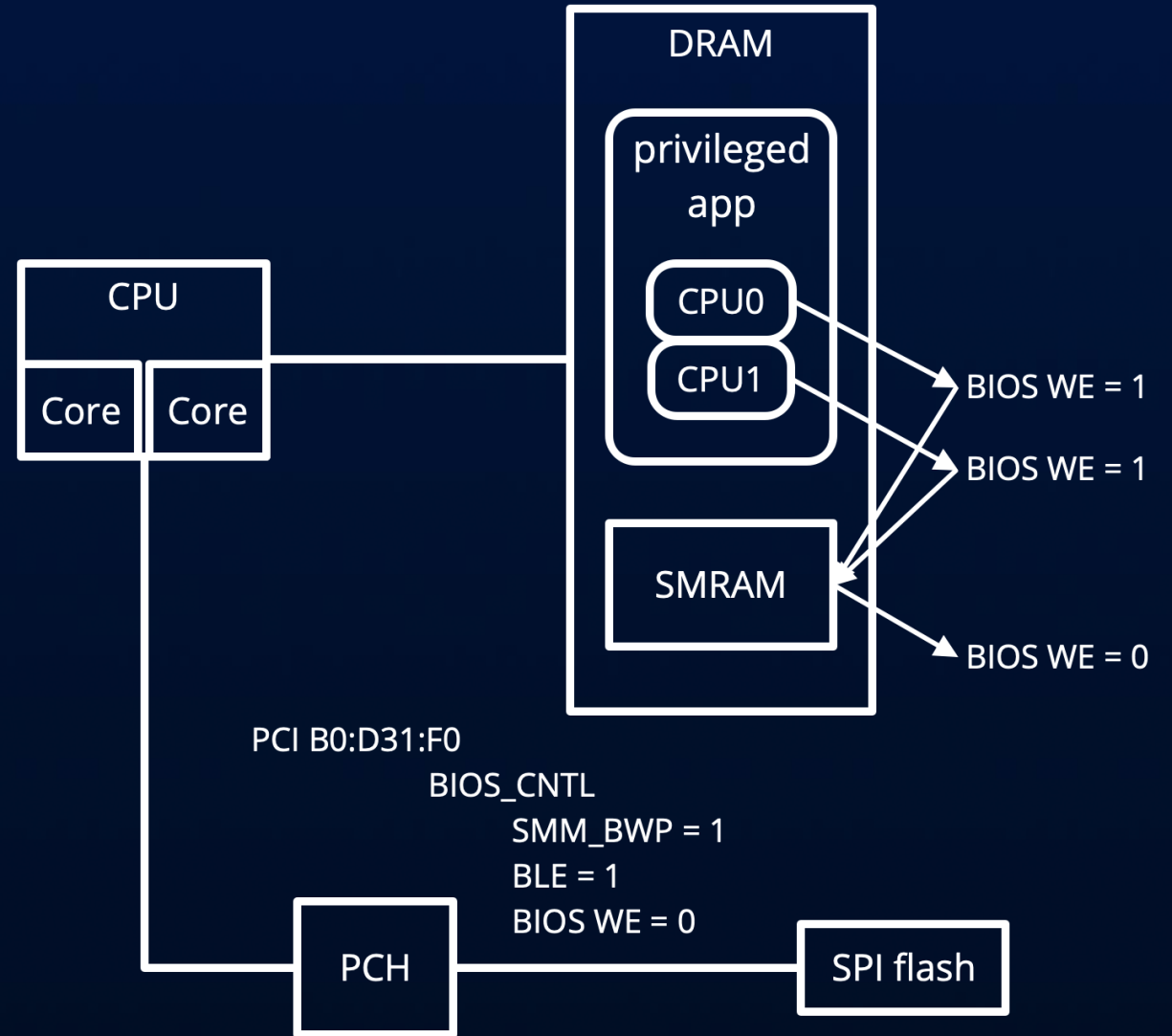

UEFI BIOS common security

BLE & SMM_BWP

SMM-based protections makes SMM code as a main target, gaining arbitrary code execution will bypass the protections.

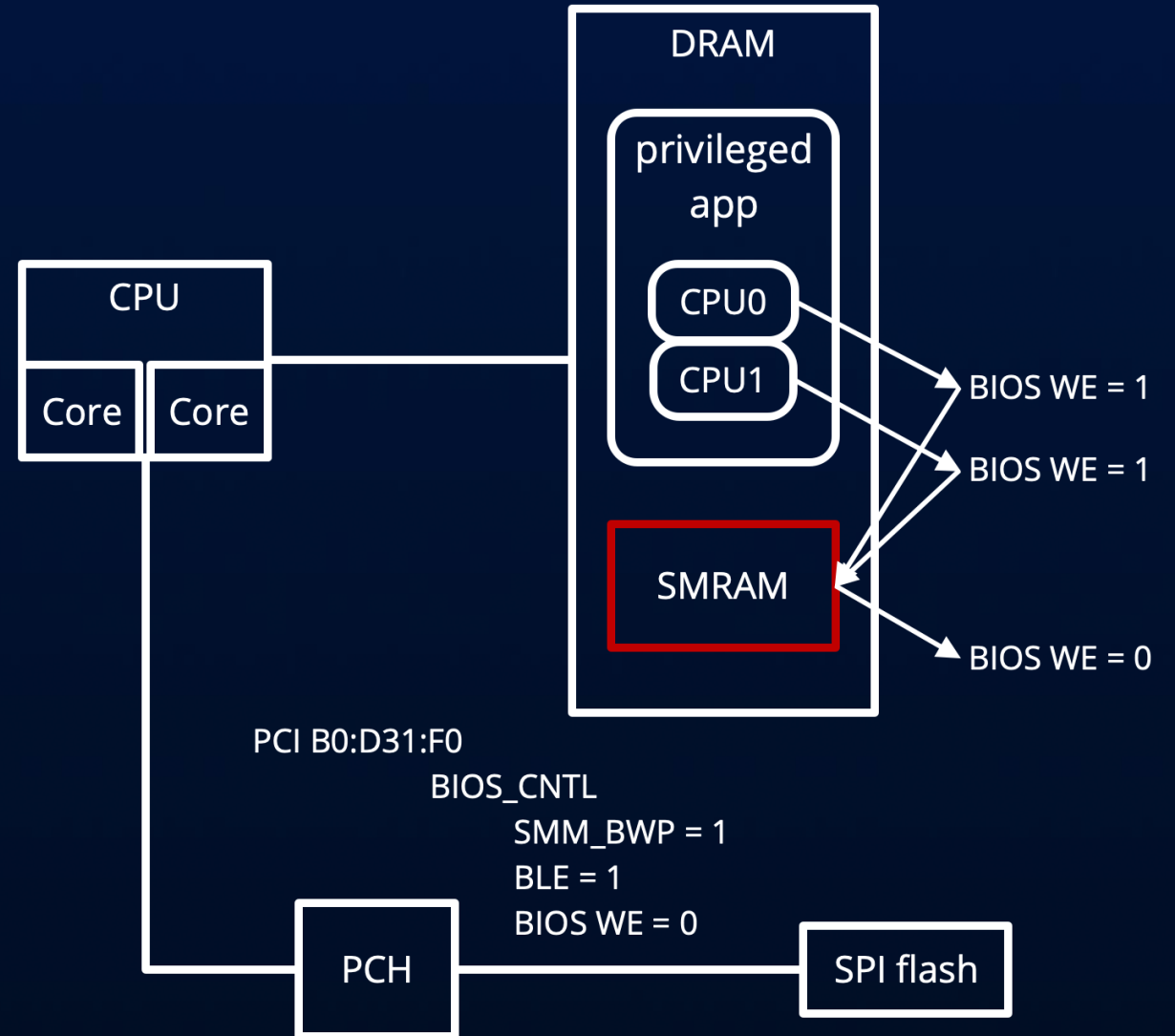

UEFI BIOS common security

Protected Ranges

Potential bypasses:

- Misconfigurations
 - FLOCKDN not set
 - Not all code-containing BIOS regions are marked
- S3 bootscrip attacks
- S3 boot path attacks (SMM)
- BIOS update procedure

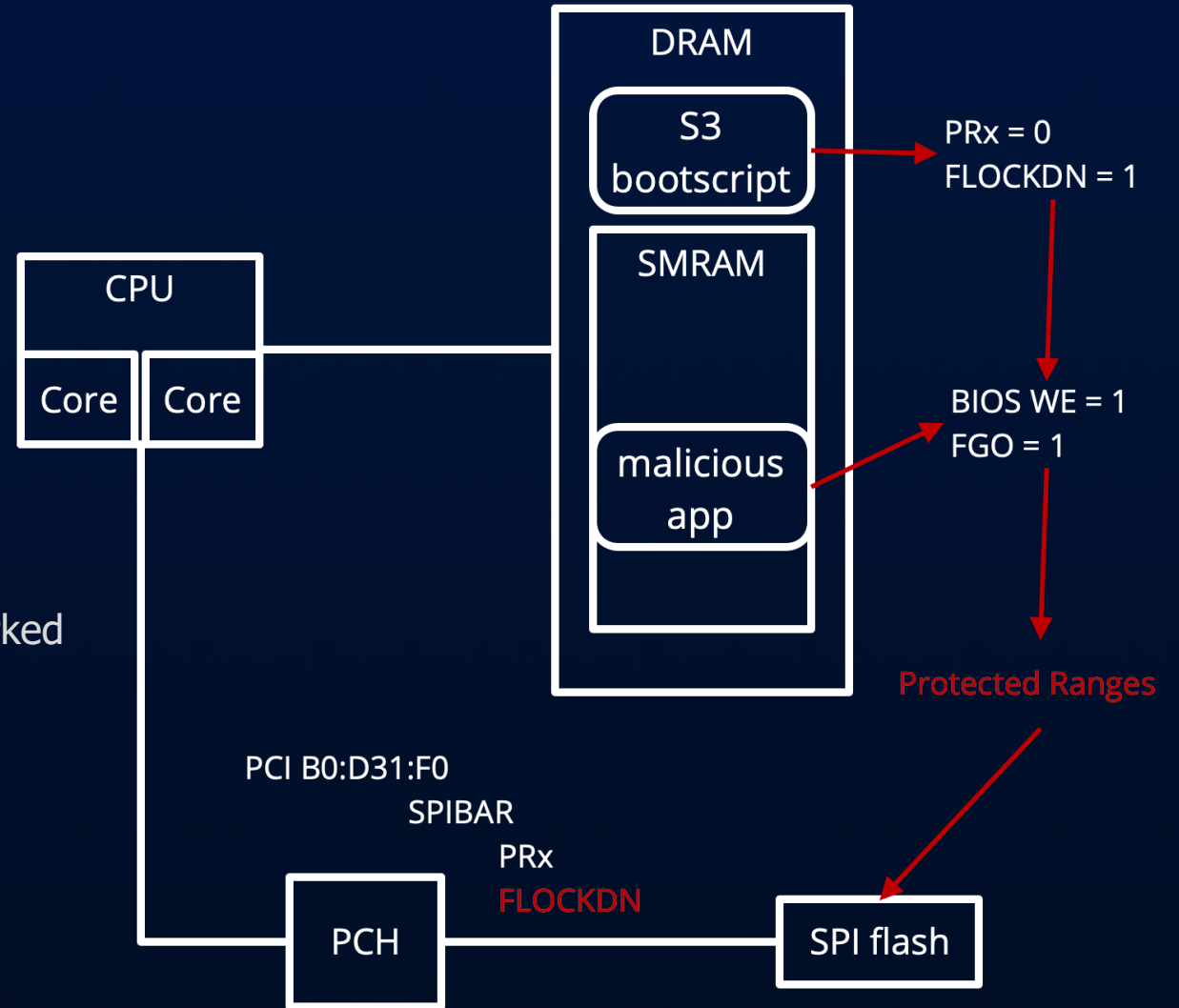

[Adventures From UEFI Land: the Hunt For the S3 Boot Script](#) by By Assaf Carlsbad & Itai Liba

UEFI BIOS hardened security

Intel BIOS Guard

Aka Platform Flash Armoring Technology (PFAT), small trusted component granted for write operations onto SPI.

It is called Intel BIOS Guard Authenticated Code Module (ACM).

Signed Flash Address Map (SFAM) structure describes what regions are marked as Signed – means, a valid certificate is required to update them.

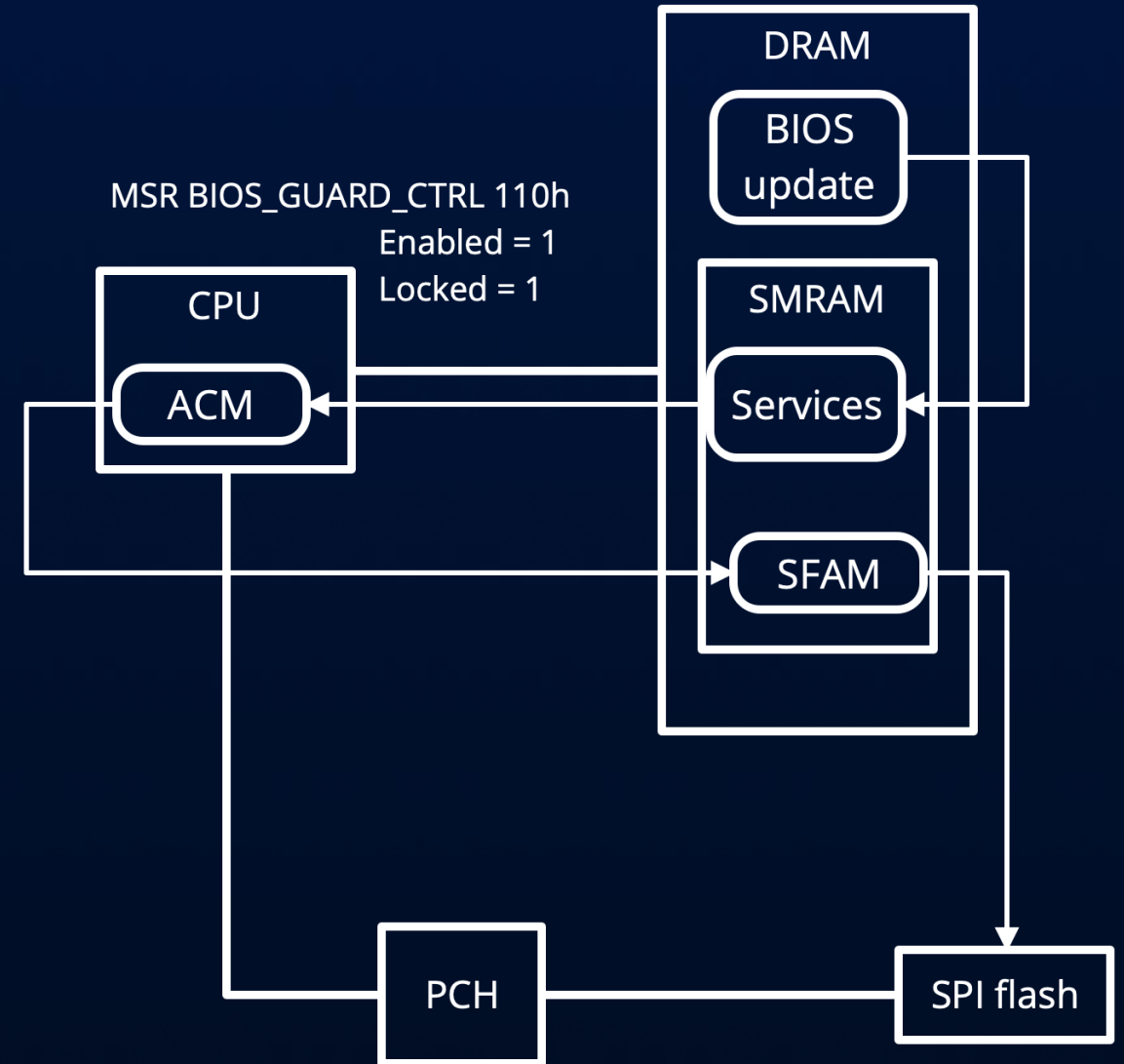

[Untrusted Roots: Exploiting Vulnerabilities in Intel ACMs by Alexander Ermolov & Dmitriy Frolov](#)

UEFI BIOS hardened security

Intel BIOS Guard

Potential bypasses:

- SFAM misconfigurations
- ACPI Embedded Controller (EC) with access to SPI
- Downgrade ACM to vulnerable version (1day)

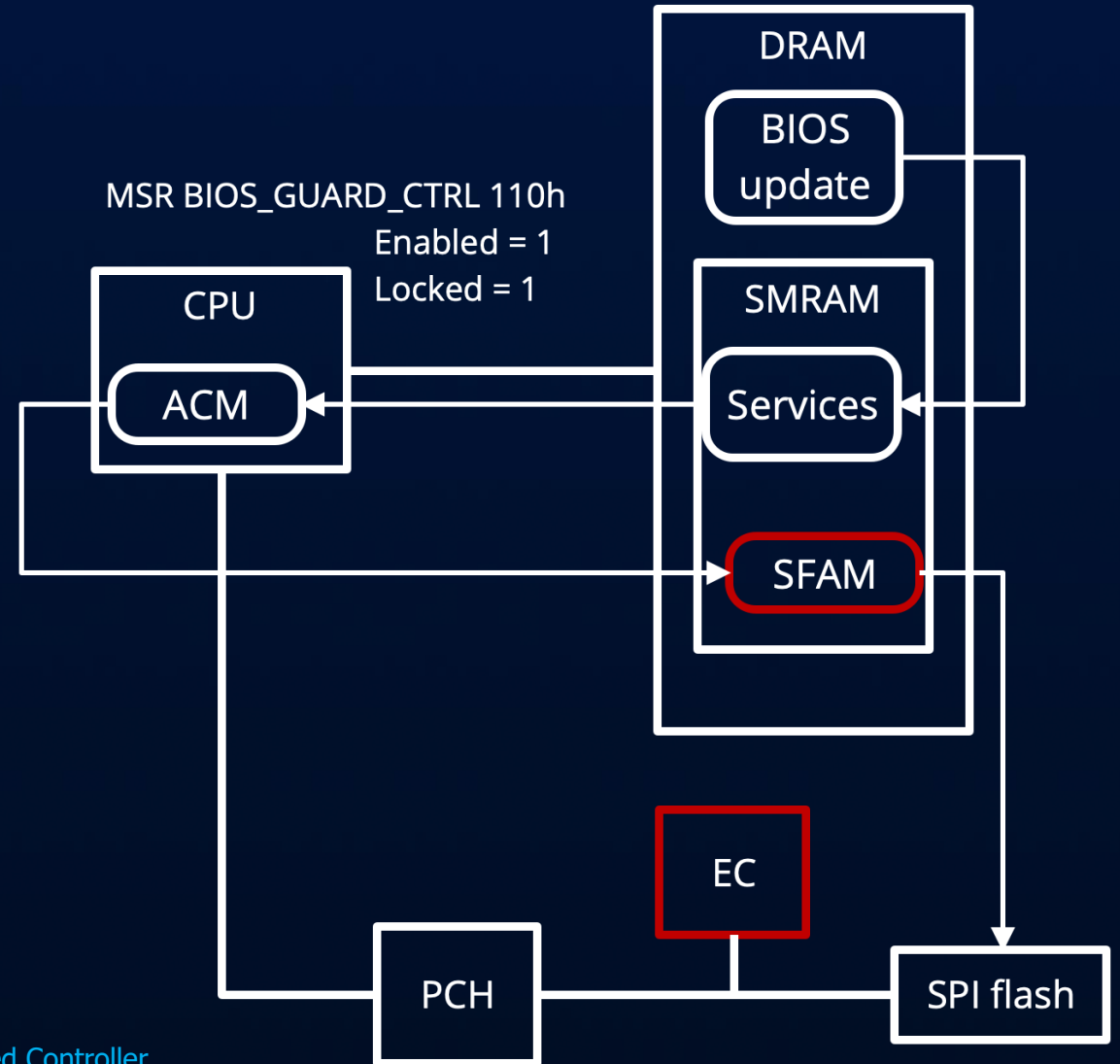

[Breaking Through Another Side. Bypassing Firmware Security Boundaries from Embedded Controller](#)
by Alex Matrosov & Alexandre Gazet

UEFI BIOS hardened security

Intel Boot Guard

Hardware-supported BIOS verification mechanism.

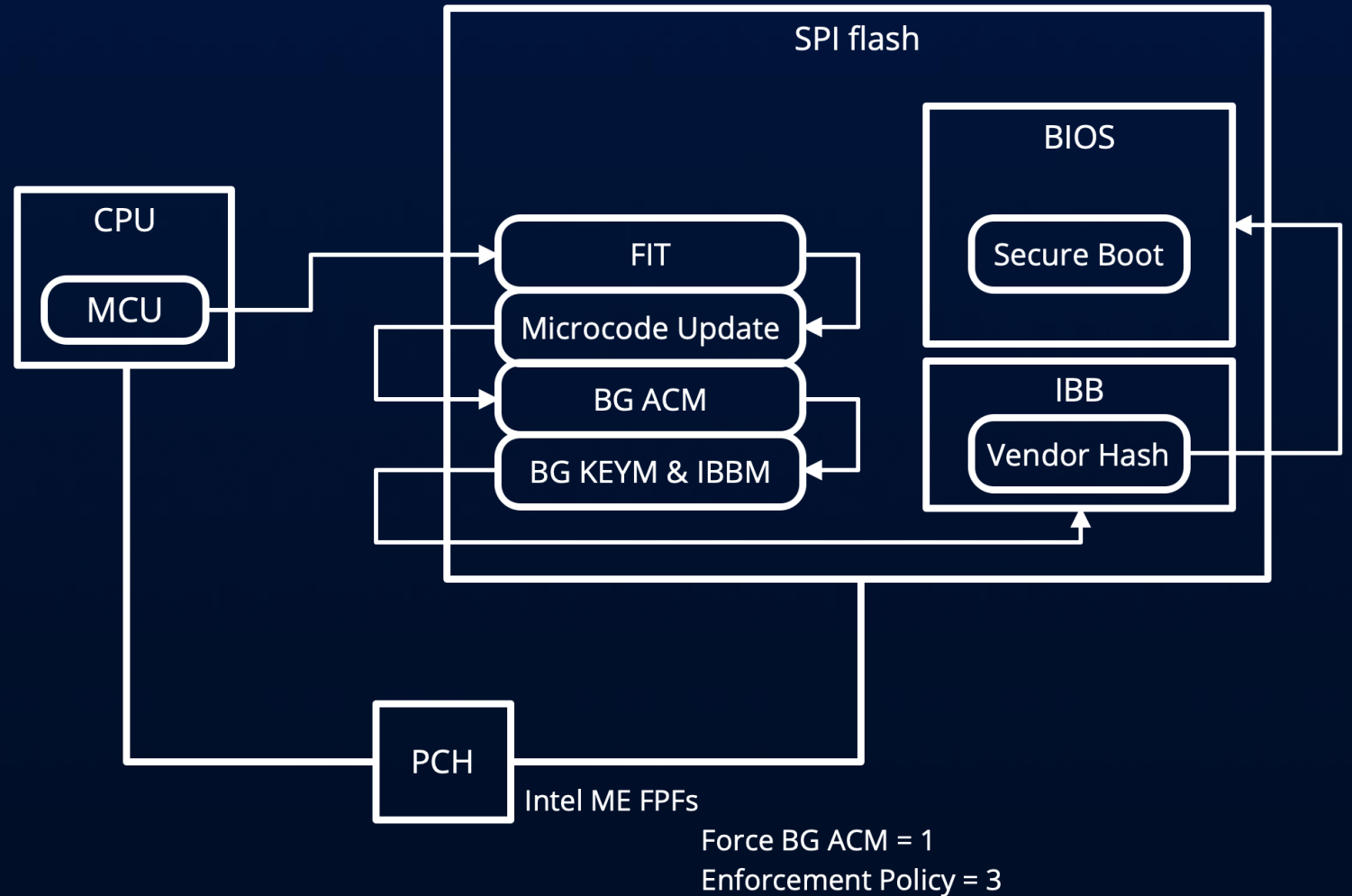

[Betraying the BIOS: where the guardians of the BIOS are failing](https://t.me/learningnets) by Alex Matrosov

UEFI BIOS hardened security

Intel Boot Guard

Potential bypasses:

- Misconfigurations
 - Fuses are not set
 - IBB hash is not covering all SEC/PEI modules
 - Vendor hash is not covering all DXE modules
 - Downgrade MCU to vulnerable version

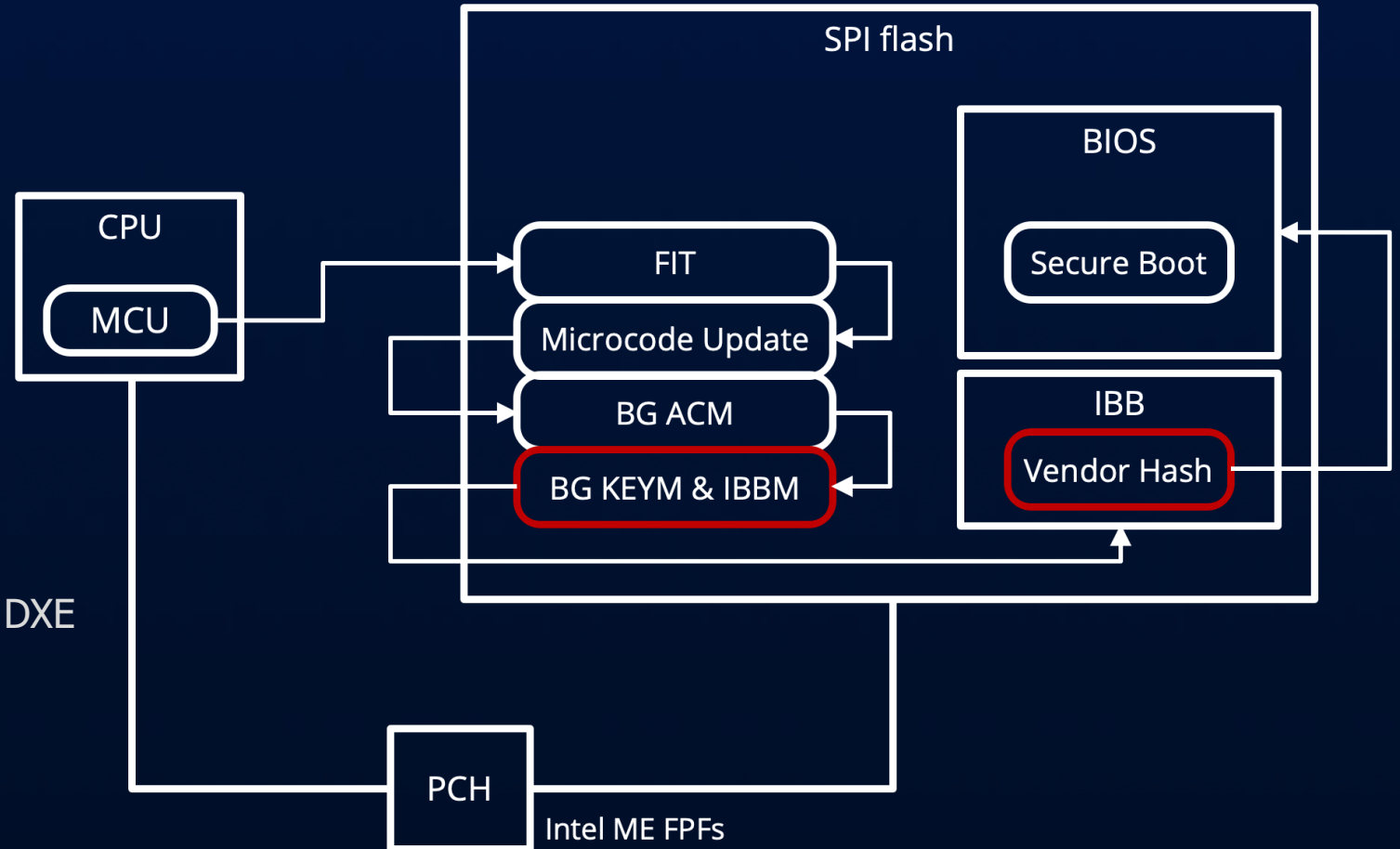

[Betraying the BIOS: where the guardians of the BIOS are failing](#) by Alex Matrosov

[Bypassing Intel Boot Guard](#) by Alexander Ermolov

[TOCTOU Attacks Against BootGuard](#) by Peter Bosch & Trammell Hudson

[\[BRLY-2021-002\] LENOVO SYSTEM FIRMWARE HAS MISSING COVERAGE WITH BOOT GUARD PROTECTED RANGES \(IBB\) FOR UEFI MODULES](#)

Force BG ACM = 1
Enforcement Policy = 3

SMM MITIGATIONS

UEFI BIOS mitigated security

SMM Nx-bit & Sanity Checks

The most known and widely-used mitigation, protects from SMM call-outs non-SMRAM.

- ValidateMemoryBuffer()
- ValidateMmioBuffer()
- ValidateSmramBuffer()

| | |
|-------------------------|-------------------------|
| MSR SMM_FEATURE_CONTROL | 4E0h |
| | SMM_Code_Chk_En = 1 |
| MSR SMM_MCA_CAP | 17Dh |
| | SMM_Code_Access_Chk = 1 |
| MSR IA32_SMRR_PHYSBASE | 1F2h |
| MSR IA32_SMRR_PHYSMASK | 1F3h |

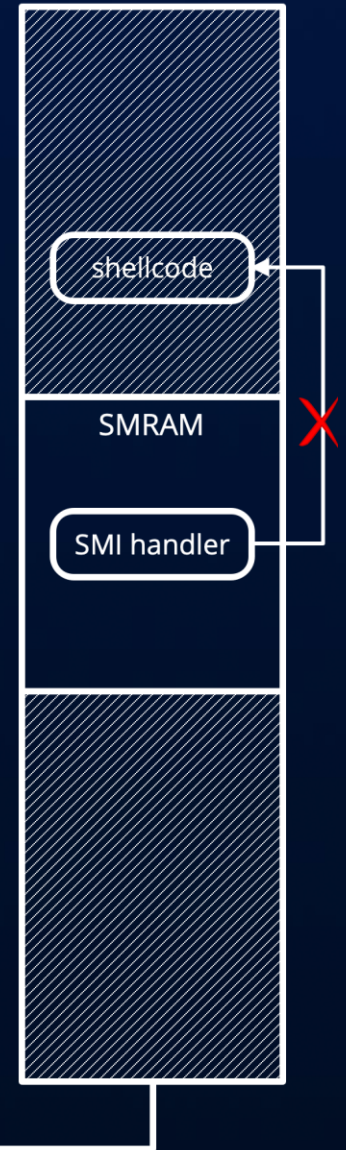

[UEFI Firmware – Securing SMM by Dick Wilkins](#)

UEFI BIOS mitigated security

IA32 (SMM) Stack/Heap Guard

Guard Page is created before and after the allocation, accessing them will cause **Page Fault**.

- For Stack it is a production-feature
Disabled by default
- For Heap it is a debug-feature
Two different builds required for Pool to get Guard page close to POOL_HEAD and POOL_TAIL).

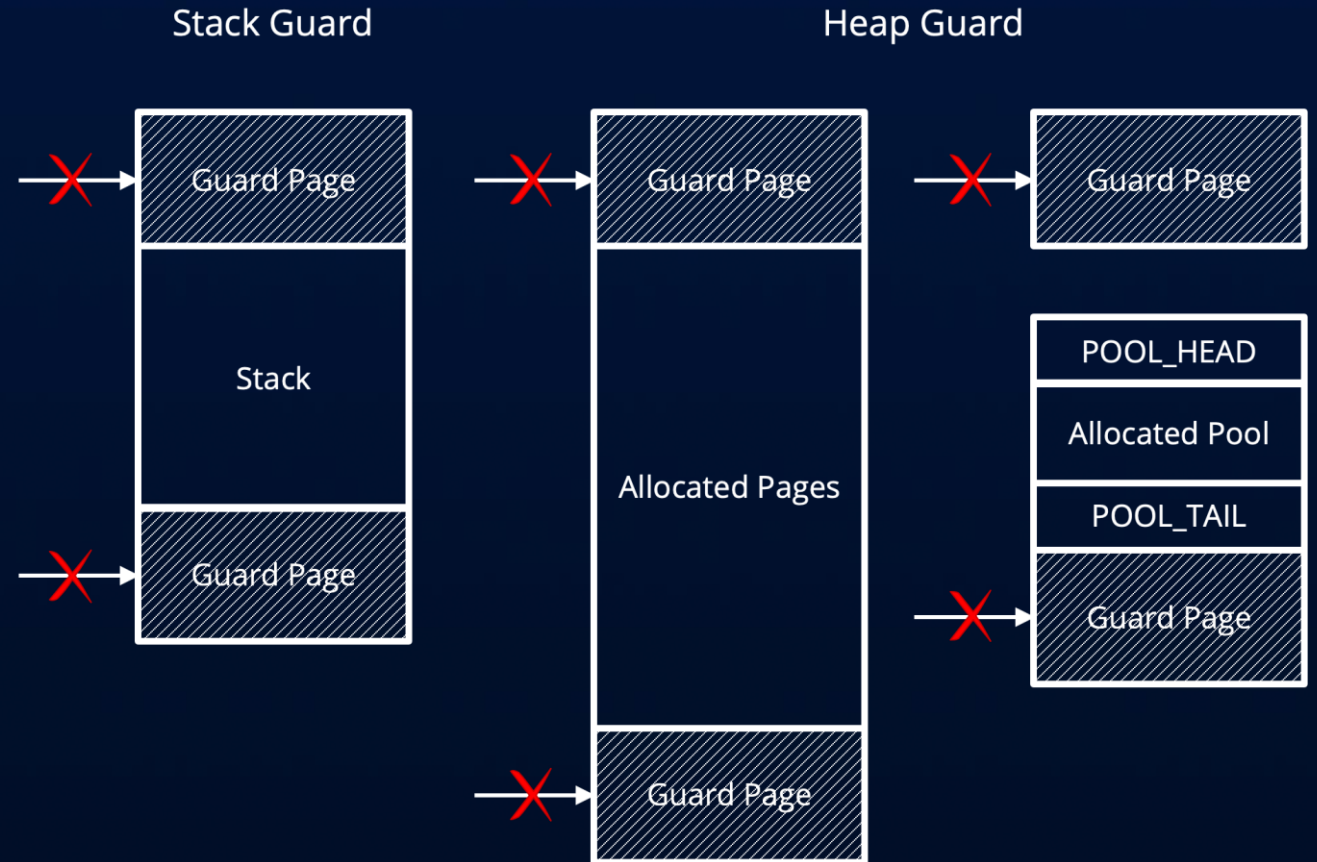

UEFI BIOS mitigated security

SMRAM memory protection (RO/XD)

Violating Read-Only / Execute-Disable attributes will cause **Segmentation Fault**.

- Page Table is dynamic by default
- Disabled by default
- ROP-attackable

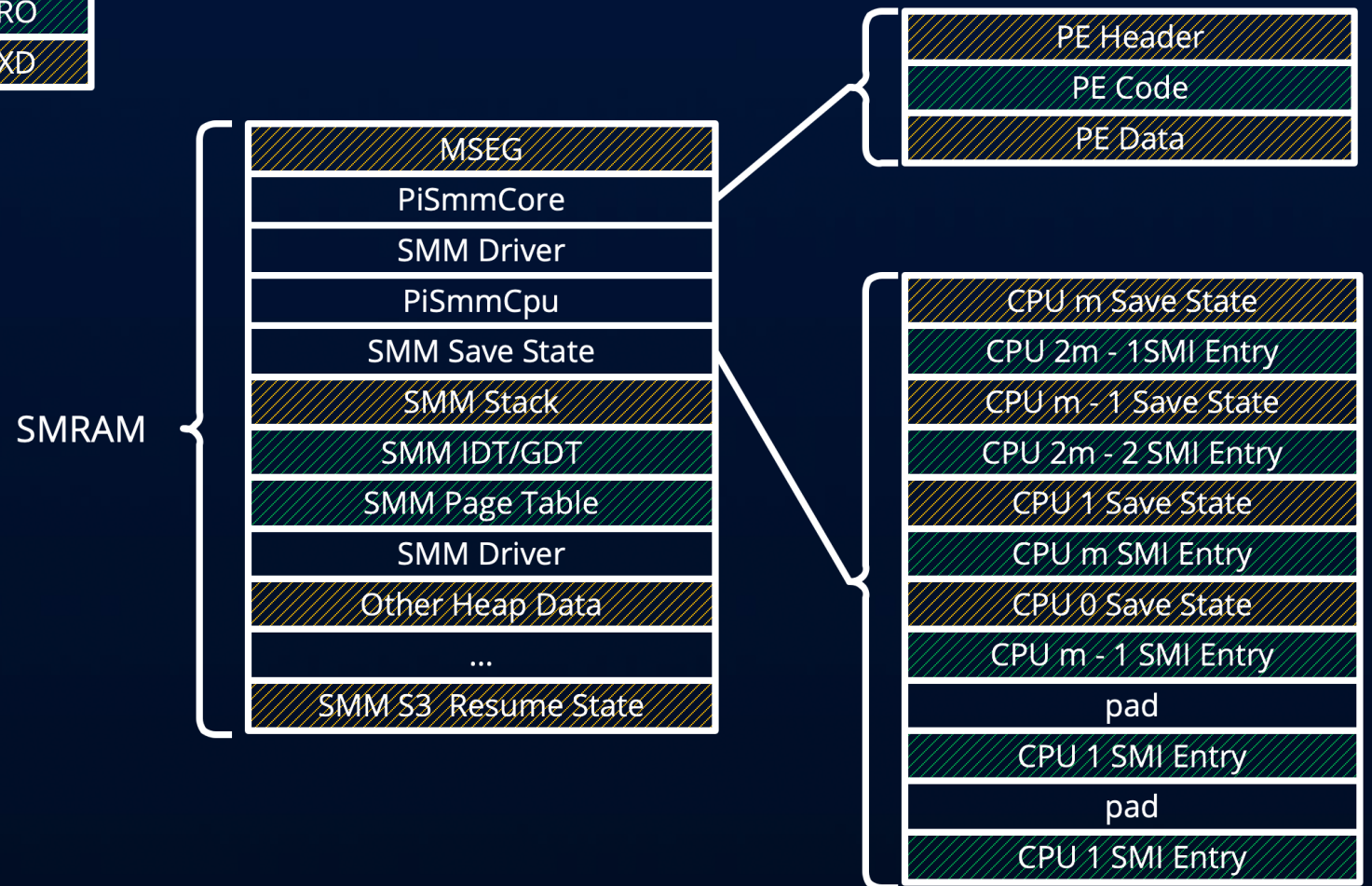

[A Tour Beyond BIOS - Memory Protection in UEFI BIOS by Jiewen Yao, Vincent J. Zimmer](#)

UEFI BIOS mitigated security

SMM static page table (RO)

SMRAM Protection + Static Page Table.

- Not compatible with Heap Guard
- Disabled by default
- ROP-attackable

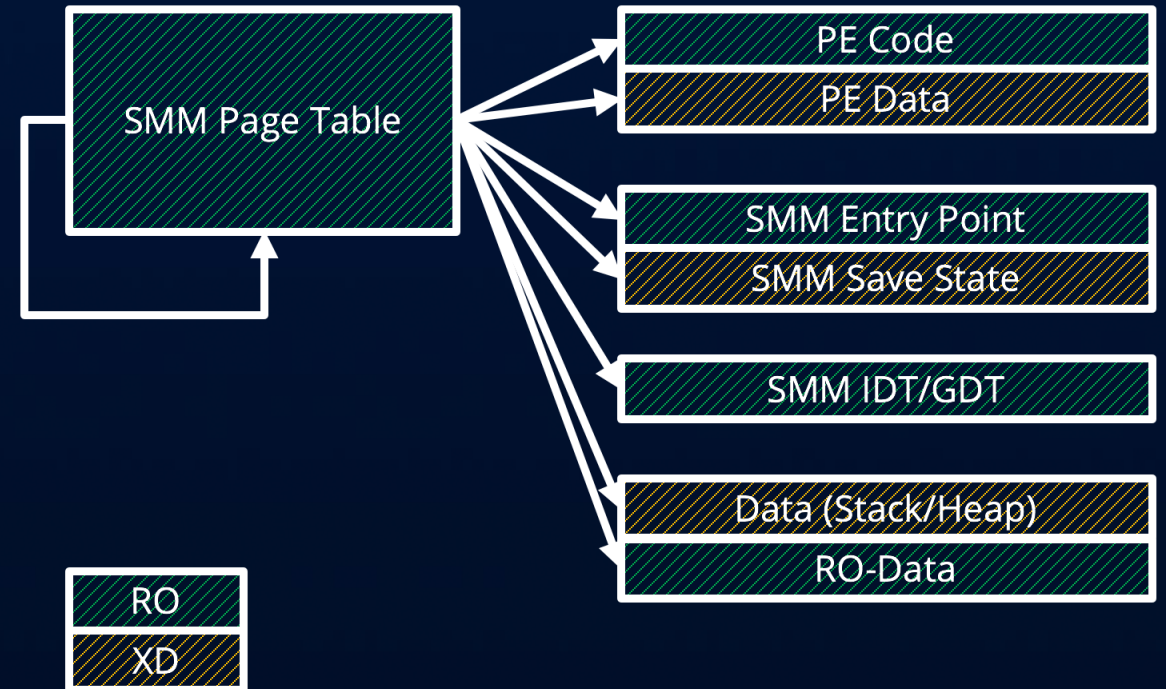

[A Tour Beyond BIOS - Memory Protection in UEFI BIOS by Jiewen Yao, Vincent J. Zimmer](https://t.me/learnignets)

UEFI BIOS mitigated security

- Address Space Layout Randomization (ASLR)

ASLR requirement in UEFI firmware

The current EDK II code does not support address space randomization. The memory allocation algorithm is top-down. In order to support the randomization in the pre-boot environment, we define below requirement:

[A Tour Beyond BIOS - Security Enhancement to Mitigate Buffer Overflow in UEFI by Jiewen Yao, Vincent J. Zimmer, Jian Wang](#)

- Intel CET (Control-flow Enforcement Technology)
exists only here:

[A Technical Look at Intel's Control-flow Enforcement Technology by Baiju V Patel](#)

UEFI BIOS mitigated security

Windows SMM Security Mitigation Table (WSMT)

This is a static ACPI table configured by vendor and stored in system memory.

<https://twitter.com/matrosov/status/1401656449965596673?s=20>



Alex Matrosov
@matrosov

WSMT (Windows SMM Security Mitigation Table) has a static nature by design which leads the results like that. The mitigation is enabled doesn't mean this mitigation is used or configured correctly.

Перевести ТВИТ



Assaf Carlsbad @assaf_carlsbad · 6 ИЮН.

UEFI firmware: All my SMI handlers will check pointers nested in the communication buffer to make sure they don't overlap with SMRAM.
SMI handler: Just pass me a pointer in the communication buffer and I'll take care of writing there.

The WSMT is a lie.

```
Administrator: PowerShell - chips x + v
C:\Users\carlsbad\Code\chipsec [wsmt_module #]> python .\chipsec_main.py --no-...
WARNING: *****
WARNING: Chipsec should only be used on test systems!
WARNING: It should not be installed/deployed on production end-user systems.
WARNING: See WARNING.txt
WARNING: *****
[CHIPSEC] API mode: using CHIPSEC kernel module API
[+] loaded chipsec.modules.common.wsmt
[+] running loaded modules ..
[+] running module: chipsec.modules.common.wsmt
[x] [ Module: WSMT Configuration
[x] [
-----
Windows SMM Mitigations Table (WSMT) Contents
-----
FIXED_COMM_BUFFERS      : True
COMM_BUFFER_NESTED_PTR_PROTECTION : True
SYSTEM_RESOURCE_PROTECTION : True
[+] PASSED: WSMT table is present and reports all supported mitigations
[CHIPSEC] ***** SUMMARY *****
[CHIPSEC] Time elapsed      0.222
[CHIPSEC] Modules total    1
[CHIPSEC] Modules failed to run 0:
[CHIPSEC] Modules passed   1:
[+] PASSED: chipsec.modules.common.wsmt
[CHIPSEC] Modules information 0:
[CHIPSEC] Modules failed     0:
[CHIPSEC] Modules with warnings 0:
[CHIPSEC] Modules not implemented 0:
[CHIPSEC] Modules not applicable 0:
[CHIPSEC] *****
C:\Users\carlsbad\Code\chipsec [wsmt_module #]> |
```

IS THAT ENOUGH?

Updated attack surface

NVRAM

Definitely not enough about secure operations with it.

- R/W area
- Not verified
- Not measured

| Intel image | Image | Intel |
|---------------------------------------|---------|--------------|
| Descriptor region | Region | Descriptor |
| GbE region | Region | GbE |
| ME region | Region | ME |
| BIOS region | Region | BIOS |
| >FA4974FC-AF1D-4E5D-BDC5-DACD6D27BAEC | Volume | FFSv2 |
| >FA4974FC-AF1D-4E5D-BDC5-DACD6D27BAEC | Volume | FFSv2 |
| Padding | Padding | Empty (0xFF) |
| >4F1C52D3-D824-4D2A-A2F0-EC40C23C5916 | Volume | FFSv2 |
| >AFDD39F1-19D7-4501-A730-CE5A27E1154B | Volume | FFSv2 |
| Pad-file | File | Pad |
| B52282EE-9B66-44B9-B1CF-7E5040F787C1 | File | Raw |
| Pad-file | | |
| >Microcode | | |
| Pad-file | | |
| BiosAc | | |
| Volume free space | | |
| >14E428FA-1A12-4875-B637-8B3CC87FDF07 | | |
| >61C0F511-A691-4F54-974F-B9A42172CE53 | | |

NVRAM

DXE

FVDATA

PEI

PEI + SEC

0xFFFFFFFFC0

Hex view: B52282EE-9B66-44B9-B1CF-7E5040F787C1

| | | |
|------|--|-------------|
| 0000 | 5F 46 49 54 5F 20 20 20 07 00 00 00 01 00 00 | _FIT_ |
| 0010 | 00 04 D7 FF 00 00 00 00 00 00 00 00 01 01 00 | ..xÿ..... |
| 0020 | 00 80 D8 FF 00 00 00 00 00 00 00 00 01 01 00 | ..ÿ..... |
| 0030 | 00 00 DA FF 00 00 00 00 00 00 00 00 01 01 00 | ..ÿ..... |
| 0040 | 00 00 F1 FF 00 00 00 00 00 00 00 00 01 02 00 | ..ñÿ..... |
| 0050 | 80 DC FC FF 00 00 00 00 00 00 00 00 01 0B 00 | ÿÿ..... |
| 0060 | 00 CC FC FF 00 00 00 00 00 00 00 00 01 0C 00 | ..ÿ..... |

Updated attack surface

The slide features a dark blue background with a glowing, abstract digital pattern of lines and dots. In the top left corner, the Black Hat logo is displayed, consisting of a white silhouette of a person wearing a hat inside a circle, followed by the text "black hat" in a bold, lowercase font, "USA 2021" in a smaller, uppercase font, and "AUGUST 4-5, 2021" and "BRIEFINGS" in even smaller, uppercase fonts. The main title is centered in a large, bold, yellow font. Below the title, the authors' names are listed in a smaller, white font. In the bottom right corner, the hashtags "#BHUSA" and "@BlackHatEvents" are visible in a small, white font.

black hat
USA 2021
AUGUST 4-5, 2021
BRIEFINGS

Safeguarding UEFI Ecosystem: Firmware Supply Chain is Hard(coded)

Alex Tereshkin, Alex Matrosov, Adam 'pi3' Zbrocki

#BHUSA @BlackHatEvents

[Safeguarding UEFI Ecosystem: Firmware Supply Chain is Hard\(coded\) by Alex Tereshkin, Alex Matrosov, Adam 'pi3' Zbrocki](#)

Updated Attack Surface

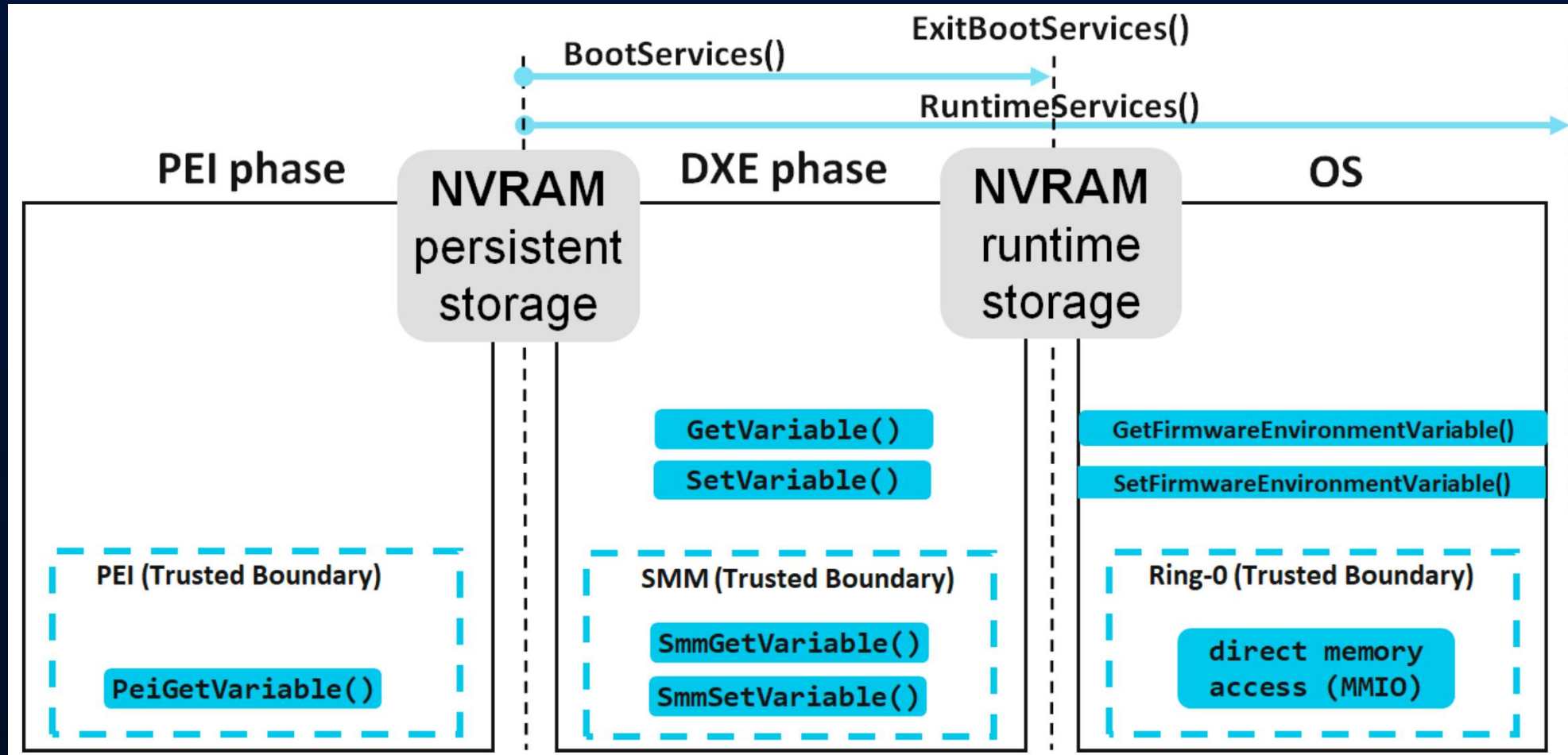

Safeguarding UEFI Ecosystem: Firmware Supply Chain is Hard(coded) by Alex Tereshkin, Alex Matrosov, Adam 'pi3' Zabrocki

AMI NVRAM driven experience

This what happens when you call EFI NVAR R/W procedures.

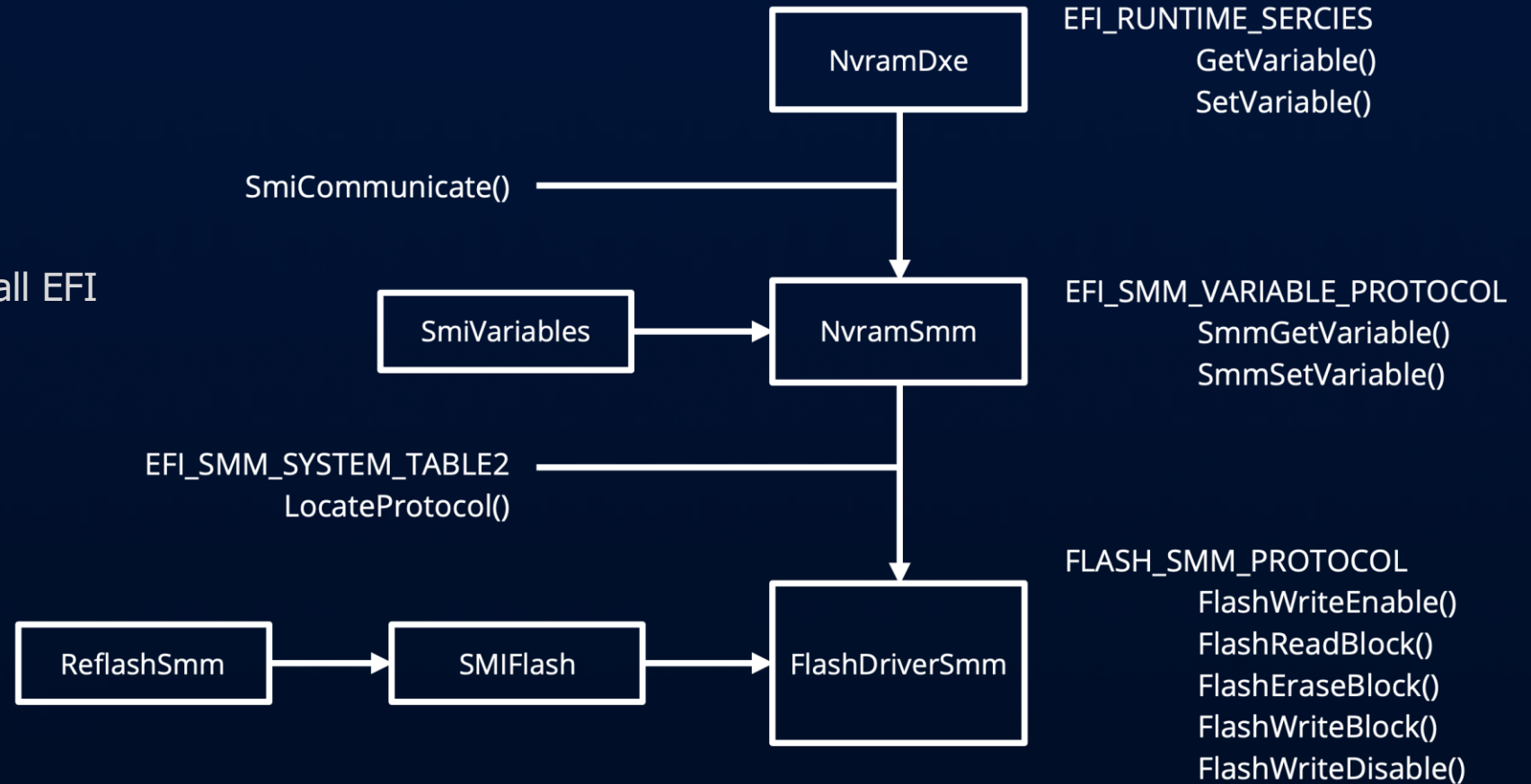

INTEL-SA-00343

CVE-2020-0530

CVSS 7.8 High

<https://www.intel.com/content/www/us/en/security-center/advisory/intel-sa-00343.html>

PEI module S3Resume2Pei {89E549B0-7CFE-449D-9BA3-10D8B2312D71}

```
// Retrieves 'FPDT_Variable_NV' EFI variable upon booting from S3 (Sleep) mode
DataSize = 4;
FDPT_ptr = 0;

if ( (*ReadOnlyVar)(ReadOnlyVar, L"FPDT_Variable_NV", &gFPDT_Variable_NV_Guid, 0, &DataSize, &FDPT_ptr) >= 0) {

    ptr = (_DWORD *) *FDPT_ptr;

    // Obviously, 'FPDT_Variable_NV' variable points to some structure, where the first field should be pointing to 'TP3S' signature
    if ( *(_DWORD *) *FDPT_ptr == 'TP3S' ) {
        if ( *((_QWORD *) FDPT_ptr + 2) ) {
            if ( !*((_WORD *) ptr + 4) ) {

                ...

                // After some basic validation a calculated values are written to the structure
                ptr[3] = v11;
                ptr[6] = result;
                ptr[7] = v12;
                ptr[4] = v7;
                ptr[5] = v9;
            }
        }
    }
}
```

PEI module SmbiosPeim {968C1D9F-80C4-43B7-8CAE-668AA56C4E71}

```
// Retrieves 'WakeUpType' EFI variable upon booting from S3 (Sleep) mode
result = (*ReadOnlyVar)(ReadOnlyVar, L"WakeUpType", &gWakeUpTypeVarGuid, 0, &DataSize, &Data);

if ( !result )
{
    if ( (unsigned int) Data <= 0xF0000 )
    {
        ...
    }
    // The value is written at address pointed by 'WakeUpType' EFI variable
    else
    {
        v4 = sub_FFFAD0F2(v3);
        LOBYTE(result) = v4[1](6);

        if ( (unsigned __int8)result >= 9u )
            LOBYTE(result) = 6;

        *Data = result;
    }
}
```

Exploitation

- Craft the 'FPDT_Variable_NV' or 'WakeUpType' EFI Variable
- Write onto NVRAM (via SMM if hardened security or RT if common security)
- Restart or Sleep/Wakeup the system

The vulnerability will be triggered upon every boot.

However we need to craft the variable (bypass all watermark checks) very carefully to gain something. Complicated, let's look into another vulnerability.

INTEL-SA-00343

CVE-2020-0526

CVSS 7.7 High

<https://www.intel.com/content/www/us/en/security-center/advisory/intel-sa-00343.html>

SMM module NvramSmm {447A1B58-8F3E-4658-ABAA-9E7B2280B90A}

```
// Retrieves NvramMailBox EFI variable

UINTN Data[3];
UINTN DataSize = 0x18;

result = gEfiSystemTable_0->RuntimeServices->GetVariable(L"NvramMailBox", &NVRAM_MAILBOX_VARIABLE_GUID, 0, &DataSize, Data);

if ( result >= 0 )
{
    ...

    // Processes the first and last QWORD from NvramMailBox

    ...

    // Deletes NvramMailBox variable
    gEfiSystemTable_0->RuntimeServices->SetVariable(L"NvramMailBox", &NVRAM_MAILBOX_VARIABLE_GUID, 0, 0, 0);

    result = gSmst_1->SmmAllocatePool(EfiRuntimeServicesData, 0x10000ui64, &Buffer);
    if ( result >= 0 )
    {
        ...
        result = gSmst_1->SmiHandlerRegister(SmiHandler, &NVRAM_MAILBOX_VARIABLE_GUID, &DispatchHandle);
        if ( result >= 0 )
        {
            // Calls a function pointed by the second QWORD from NvramMailBox!
            result = ((__int64 (*)(void)) Data[1])();
        }
    }
}
```

Exploitation

It is very simple to craft this variable so that it would lead to gaining code execution in SMM.

However at the moment of running NvramSmm this variable is already created in DXE module NvramDxe {1807040D-5934-41A2-A088-8E0F777F71AB}:

```
Data[0] = (__int64) &dword_8000E620;  
Data[1] = (__int64) sub_80001C60;  
Data[2] = (__int64) &byte_8000E924;  
  
result = SetVariable_local(L"NvramMailBox", &NvramMailBoxVarGuid, 2, 0x18, Data);
```

But since the variable is deleted in NvramSmm (with all its attributes):

```
// Deletes NvramMailBox variable  
gEfiSystemTable_0->RuntimeServices->SetVariable(L"NvramMailBox", &NVRAM_MAILBOX_VARIABLE_GUID, 0, 0, 0);
```

We can create the new one! Using just EFI_RUNTIME_SERVICES->SetVariable() with NON_VOLATILE | RUNTIME_ACCESS | AUTH_ACCESS attributes to lock it for NvramDxe.

Exploitation

- Build payload
- Write onto NVRAM (via SMM if hardened security or RT if common security)
- Craft the 'NvramMailBox' EFI Variable so its second QWORD will point to the payload inside NVRAM and with attributes to lock it for boot phase
- Restart the system

The payload will be executed upon every boot

Tested on Intel® NUC Kit NUC7i7BNH

Impact

- This vulnerability bypasses all known BIOS protection mechanisms since:
 - NVRAM is a R/W area by design not measured/verified
 - Lack of anti-exploit mitigations (no ASLR, no Memory Guards, no RO/XD etc.)
- Ring 3 admin no SMM required API
- Good point is:

Given different patch cycles across vendors, these vulnerabilities can stay unpatched on endpoint devices for 6-9 months (sometimes even longer).

[Firmware Supply Chain is Hard\(Coded\) by Binarly team](#)

- Even if BIOS stored in Apple T2 security chip (you can still exploit memory corruptions in NVRAM)

NVRAM STORIES

with efiXplorer

Thanks to Yegor Vasilenko [@yeggory](#) for helping with this part

<https://github.com/binary-io/efiXplorer>

Load & Scan

Testing efiXloader / efiXplorer on some old buggy firmware.

Results:

- a few SMM callouts
- a few GetVariable() buffer overflows

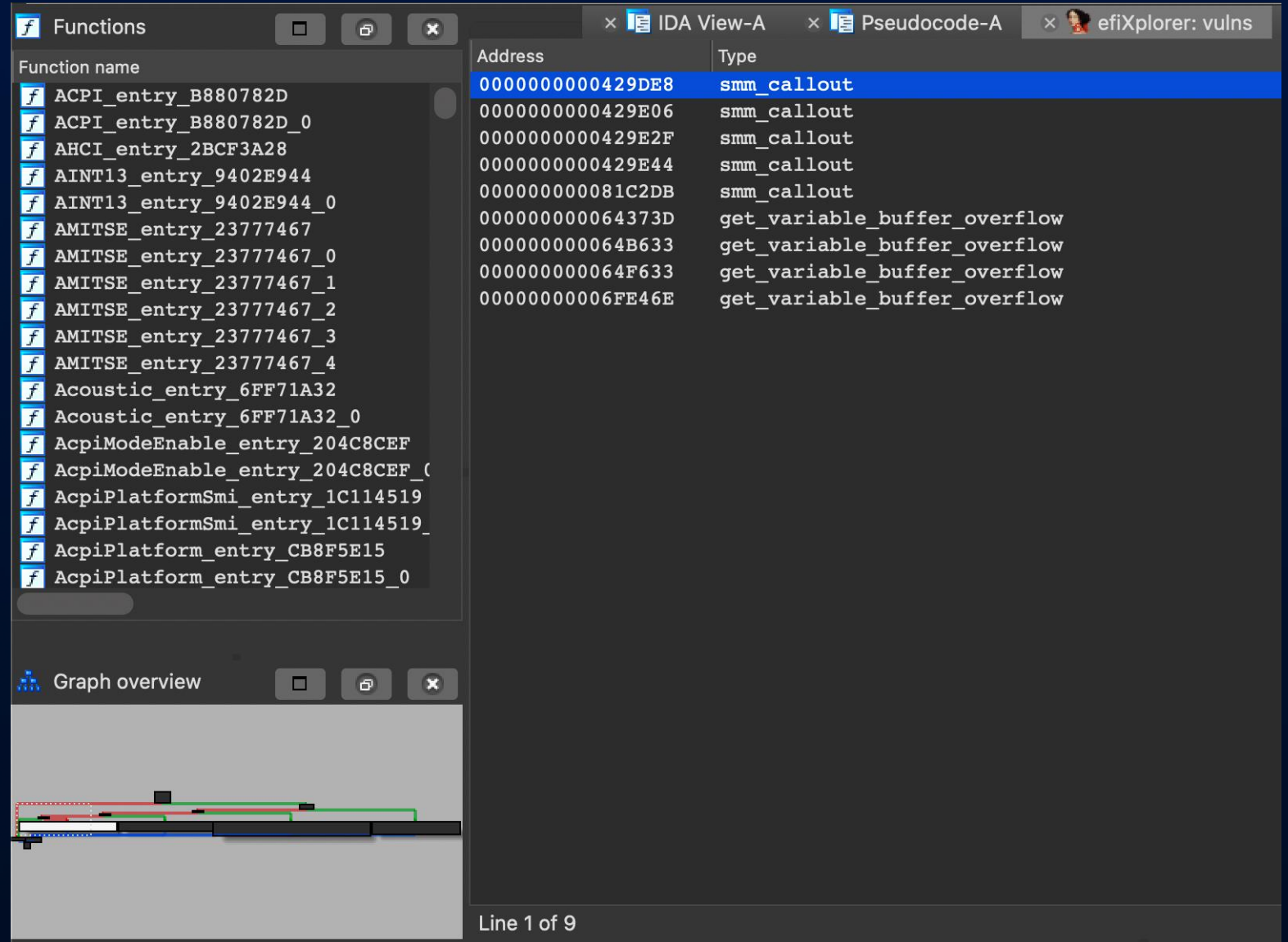

The screenshot shows the IDA Pro interface with the 'Functions' window on the left and a table of addresses and types on the right. The 'Functions' window lists various entry points, including several 'AMITSE_entry' and 'AcpiPlatformSmi_entry' functions. The table on the right lists the addresses and types for these functions, with the first entry highlighted in blue.

| Address | Type |
|------------------|------------------------------|
| 0000000000429DE8 | smm_callout |
| 0000000000429E06 | smm_callout |
| 0000000000429E2F | smm_callout |
| 0000000000429E44 | smm_callout |
| 000000000081C2DB | smm_callout |
| 000000000064373D | get_variable_buffer_overflow |
| 000000000064B633 | get_variable_buffer_overflow |
| 000000000064F633 | get_variable_buffer_overflow |
| 00000000006FE46E | get_variable_buffer_overflow |

GetVariable() buffer overflow

GetVariable() used to retrieve the size of the variable, which further is ignored.

```
IDA View-A Pseudocode-A efiXplorer: vulns Hex View-1 Structures Enums
__int64 __fastcall sub_64F590(unsigned __int16 a1, __int64 a2)
{
    // [COLLAPSED LOCAL DECLARATIONS. PRESS KEYPAD CTRL-"+" TO EXPAND]

    DataSize = 0i64;
    v9 = 1280i64;
    gBS_6526B0->LocateProtocol(&EFI_HII_STRING_PROTOCOL_GUID_651C78, 0i64, &Interface);
    v4 = gRT_6526B8->GetVariable(L"PlatformLang", &EFI_SIMPLE_BOOT_FLAG_VARIABLE_GUID_651BB0, 0i64, &DataSize, Data);
    if ( v4 == EFI_BUFFER_TOO_SMALL )
        v4 = gRT_6526B8->GetVariable(L"PlatformLang", &EFI_SIMPLE_BOOT_FLAG_VARIABLE_GUID_651BB0, 0i64, &DataSize, Data);
    if ( v4 >= 0 )
        return (Interface->GetString)(Interface, Data, qword_652728, a1, a2, &v9, 0i64);
    else
        return EFI_NOT_FOUND;
}
```

SMM call-outs

Usage of
EFI_RUNTIME_SERVICES
in SMI Handler.

```
EFI_STATUS sub_429DAC()
{
    // [COLLAPSED LOCAL DECLARATIONS. PRESS KEYPAD CTRL-"+" TO EXPAND]

    v0 = qword_42AE08;
    if ( *qword_42AE08 != 'RAVN' )
        return EFI_DEVICE_ERROR;
    switch ( *(qword_42AE08 + 40) )
    {
        case 1:
            result = gRT_42AE28->GetVariable(
                (qword_42AE08 + 72),
                (qword_42AE08 + 8),
                (qword_42AE08 + 4),
                (qword_42AE08 + 24),
                (qword_42AE08 + 72));

            break;
        case 2:
            result = gRT_42AE28->SetVariable(
                (*(qword_42AE08 + 24) + qword_42AE08 + 72),
                (qword_42AE08 + 8),
                *(qword_42AE08 + 4),
                *(qword_42AE08 + 24),
                (qword_42AE08 + 72));

            break;
        case 3:
            result = gRT_42AE28->GetNextVariableName((qword_42AE08 + 24), (qword_42AE08 + 72), (qword_42AE08 + 8));
            break;
        case 4:
            result = gRT_42AE28->QueryVariableInfo(
                *(qword_42AE08 + 4),
                (qword_42AE08 + 48),
                (qword_42AE08 + 56),
                (qword_42AE08 + 64));

            break;
        default:
            return EFI_DEVICE_ERROR;
    }
    *(v0 + 32) = result;
    *(v0 + 40) = 0;
    *v0 = 0xADBEA9B1;
    return result;
}
```

SmmGetVariable() buffer overflow

| Address | Type |
|------------------|----------------------------------|
| 0000000000003527 | smm_get_variable_buffer_overflow |

```
__int64 sub_34B8()
{
    __int64 result; // rax
    char Data; // [rsp+48h] [rbp+18h] BYREF
    UINT32 Attributes; // [rsp+50h] [rbp+20h] BYREF
    UINTN DataSize; // [rsp+58h] [rbp+28h] BYREF

    DataSize = 0i64;
    result = gSmmVar_5B40->SmmGetVariable(gVariableName1, &gVendorGuid, &Attributes, &DataSize, 0i64);
    if ( result == EFI_BUFFER_TOO_SMALL )
    {
        result = gSmmVar_5B40->SmmGetVariable(gVariableName1, &gVendorGuid, &Attributes, &DataSize, &Data);
        if ( result >= 0 )
        {
            DataSize = 0i64;
            (gSmmVar_5B40->SmmSetVariable)(gVariableName1, &gVendorGuid, Attributes, 0i64, 0i64);
            DataSize = 1i64;
            return (gSmmVar_5B40->SmmSetVariable)(gVariableName2, &gVendorGuid, Attributes);
        }
    }
    else if ( result == 0x8000000000000000Eui64 )
    {
        return 0i64;
    }
    return result;
}
```

Outcomes

- Vector to bypass all known protections
- UEFI BIOS attack surface keeps extending:
 - More NVRAM format & EFI variable parsing code
 - More UEFI API for the runtime (Redfish etc.)
- Even a signed firmware can't be trusted (c) Binarly

Mitigations

- Enforce mitigations
- Type safe languages

THANK YOU

