OFF-PATH ATTACKS AGAINST PUBLIC KEY INFRASTRUCTURES

Markus Brandt, Tianxiang Dai, Elias Heftrig, Amit Klein, Haya Shulman, Michael Waidner

AGENDA

- Objectives
- Attacking
- Impact
- Mitigation
- Summary

AGENDA

- Objectives
- Attacking
- Impact
- Mitigation
- Summary

WEB PKI – WHAT IS IT GOOD FOR?

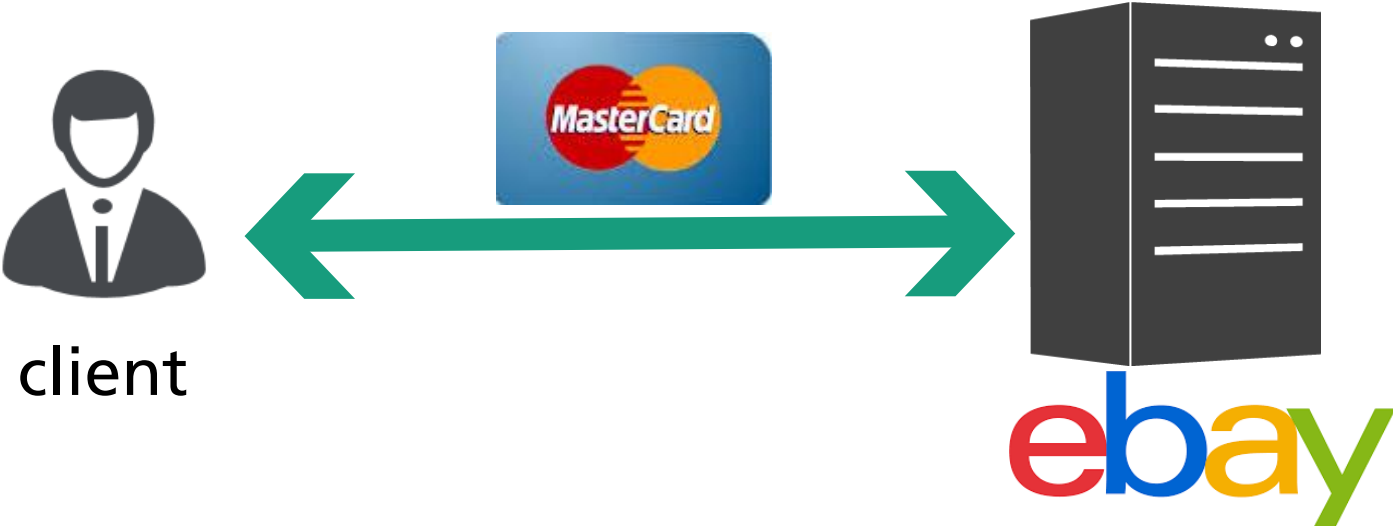

WEB PKI UNSECURED COMMUNICATION

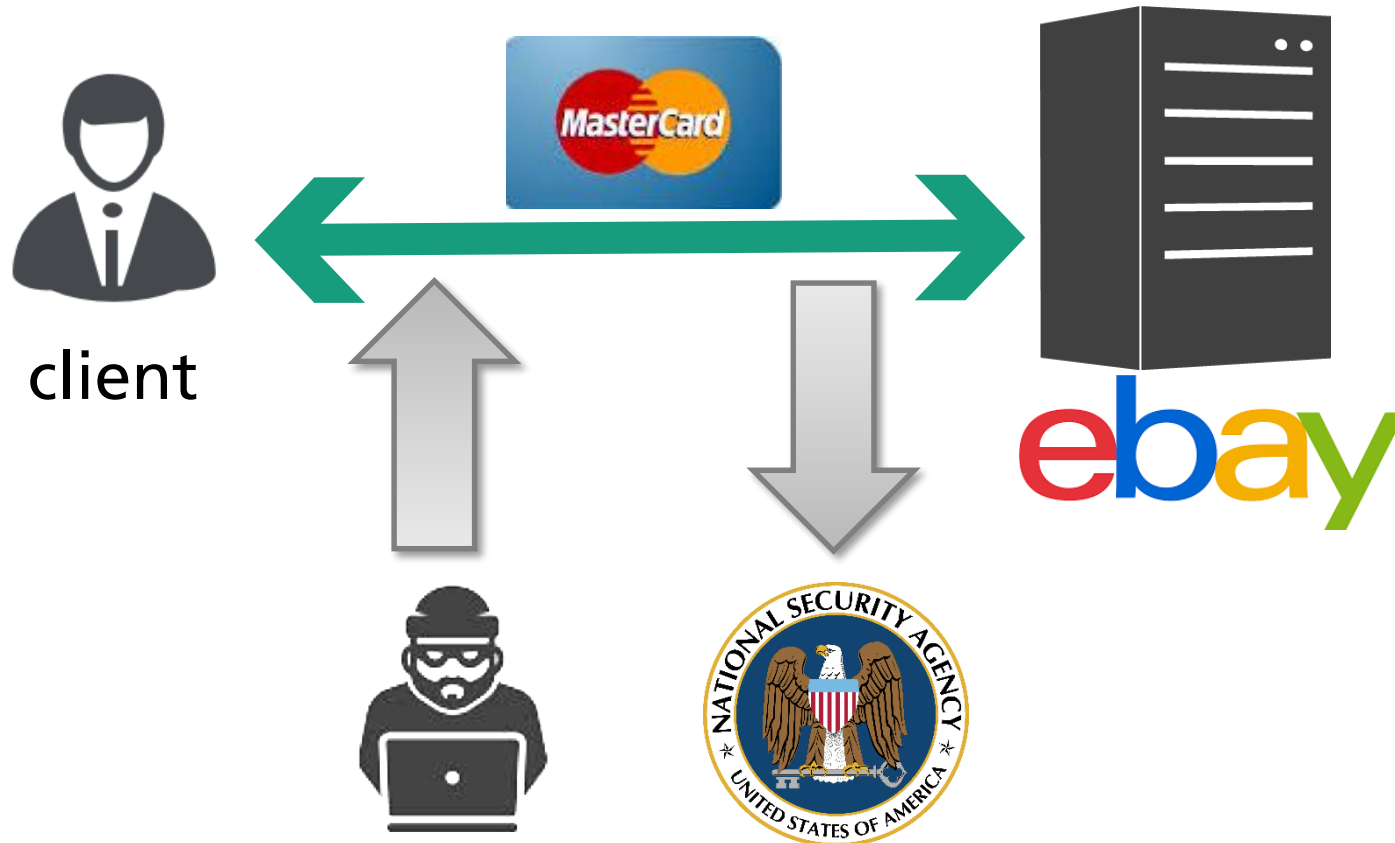

WEB PKI SECURED COMMUNICATION

Certificate is signed by trusted CA

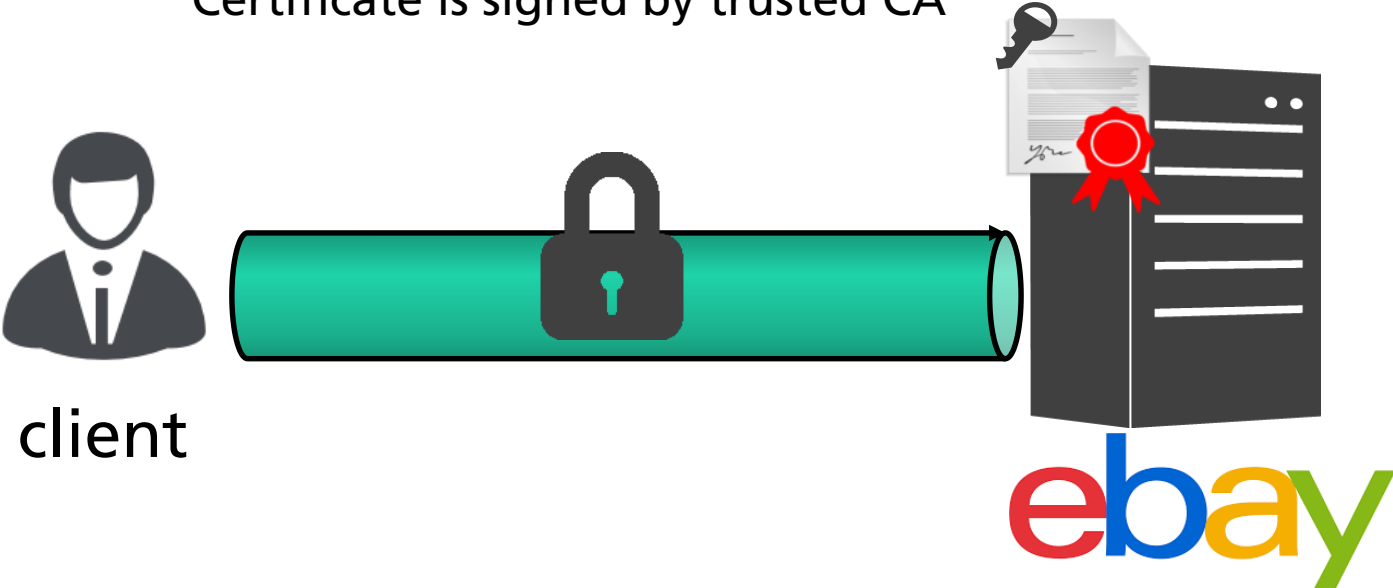

WEB PKI SECURE AGAINST SPOOFING

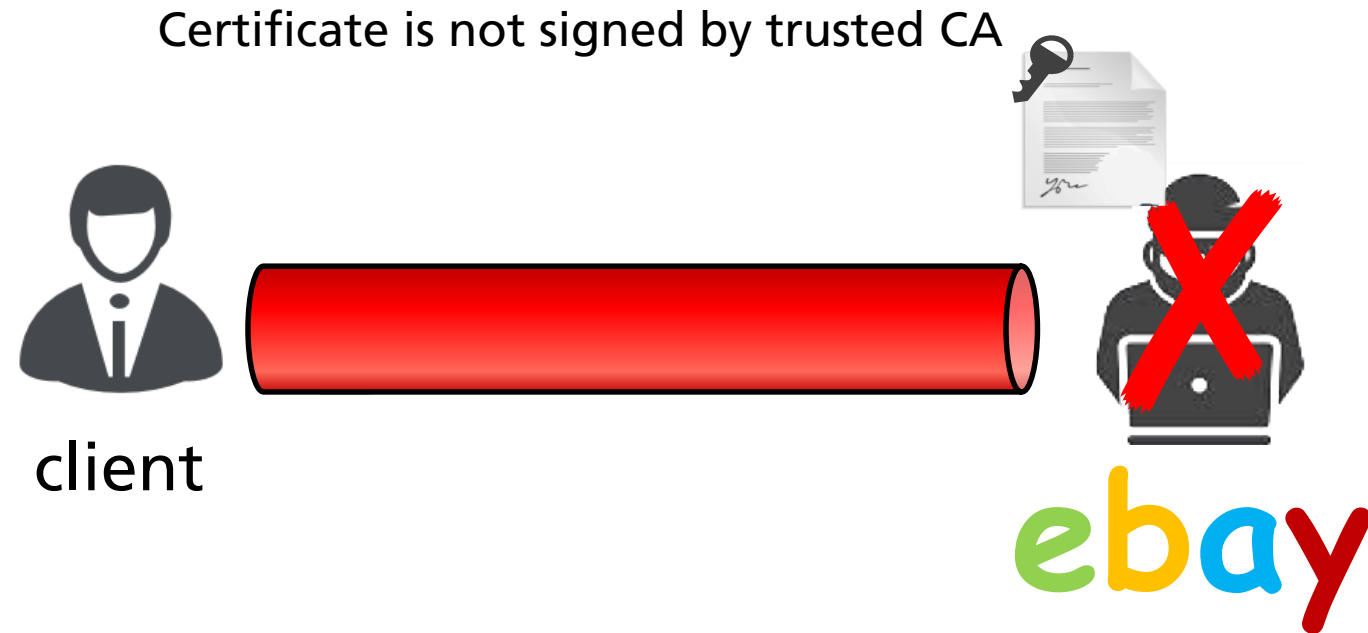

ATTACKER MODEL

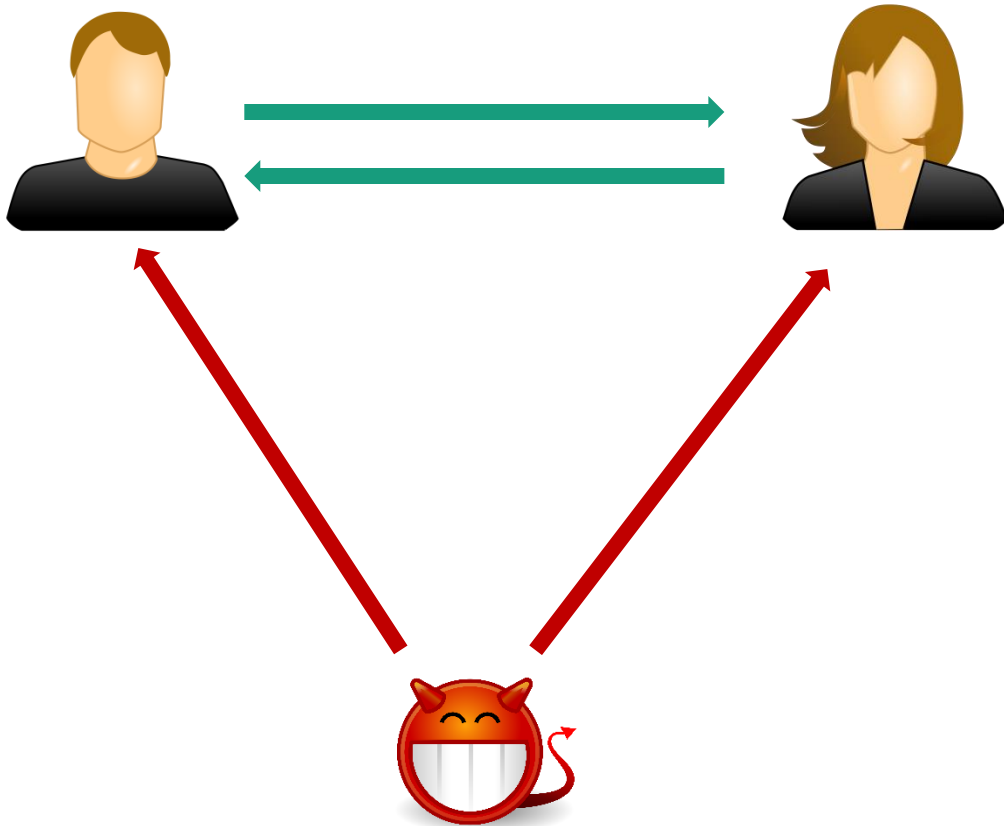

- Off-path attacker
 - cannot eavesdrop, block, delay or modify packets in any way
 - injects packets with spoofed sender address

- Means of Attack
 - leverage IP defragmentation cache poisoning
 - to achieve DNS cache poisoning
 - for exploiting Domain Validation

CERTIFICATE ISSUANCE WITH DOMAIN VALIDATION

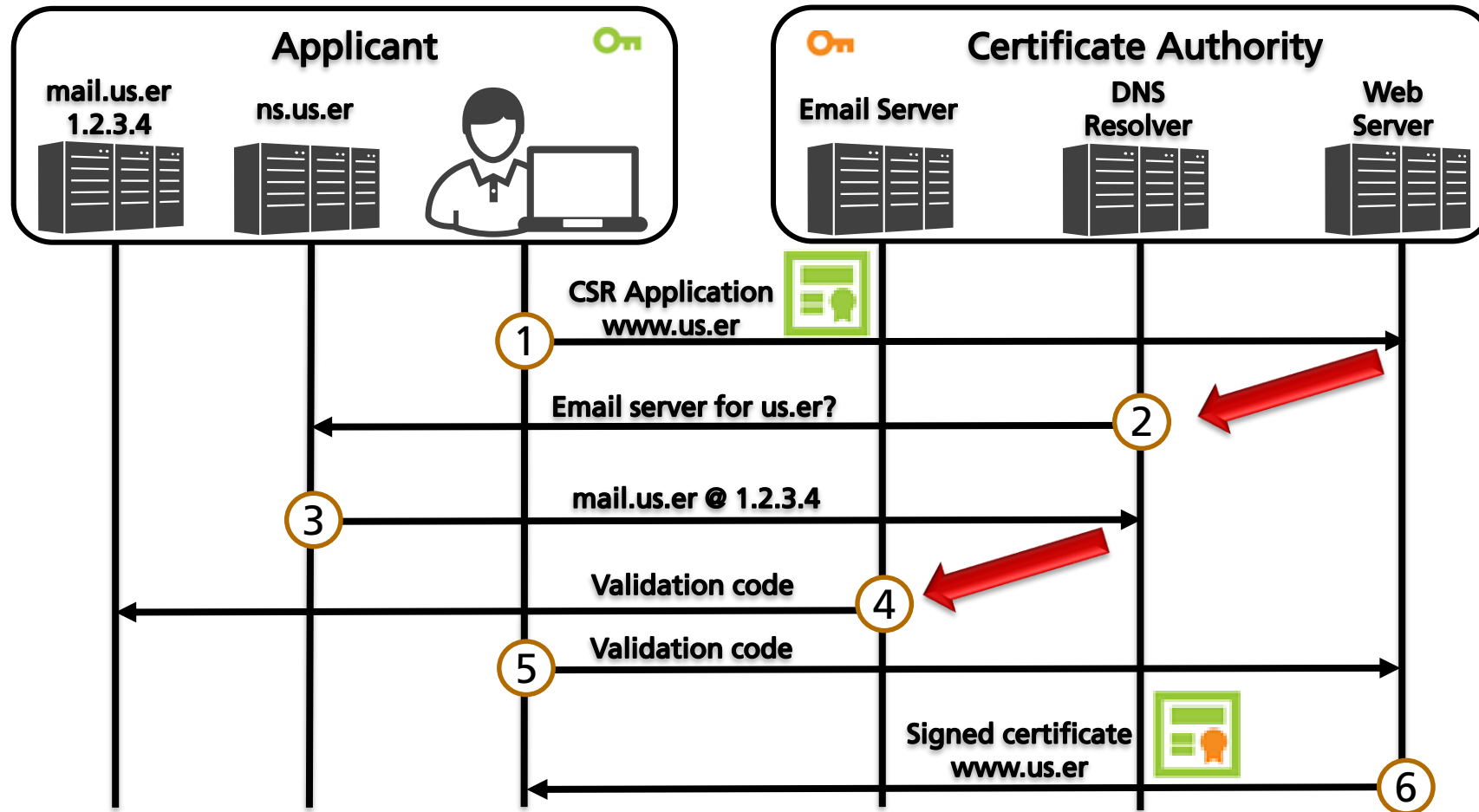

DNS - QUERIES

The yellow pages of the Internet



DNS - QUERIES

If cached the resolver will reply with the cached answer

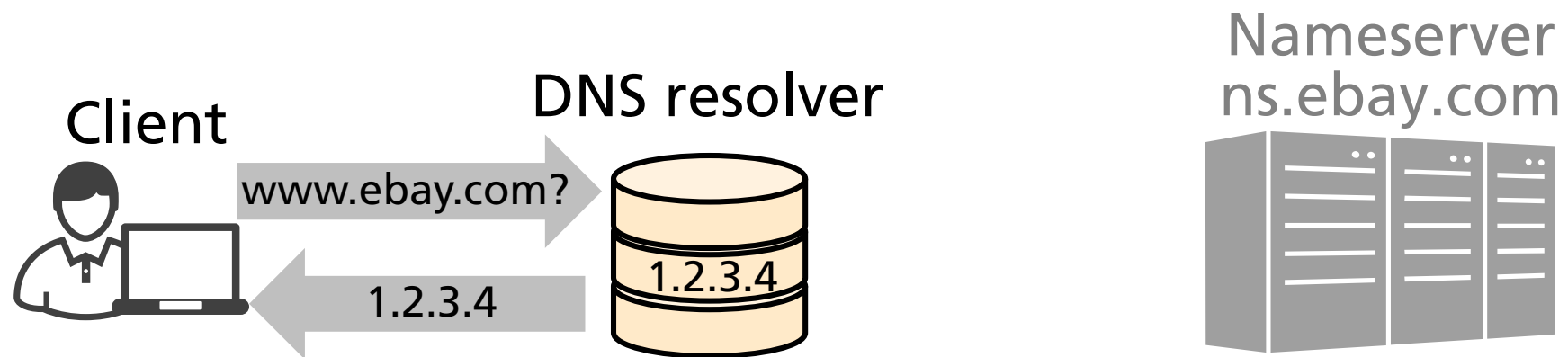

DNS - QUERIES

If not cached the resolver will recursively lookup the answer



DNS - QUERIES



DNS - QUERIES

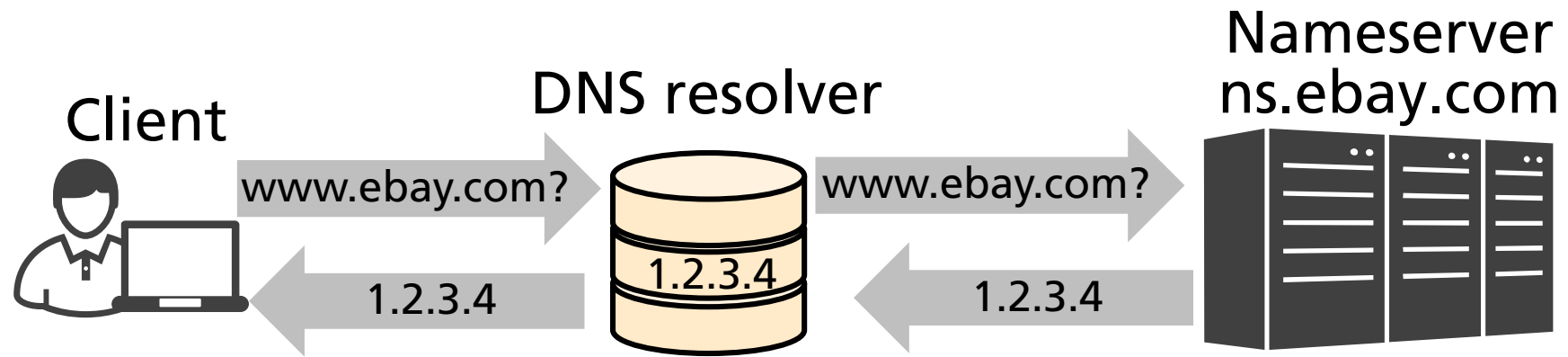

DNS – CACHE POISONING

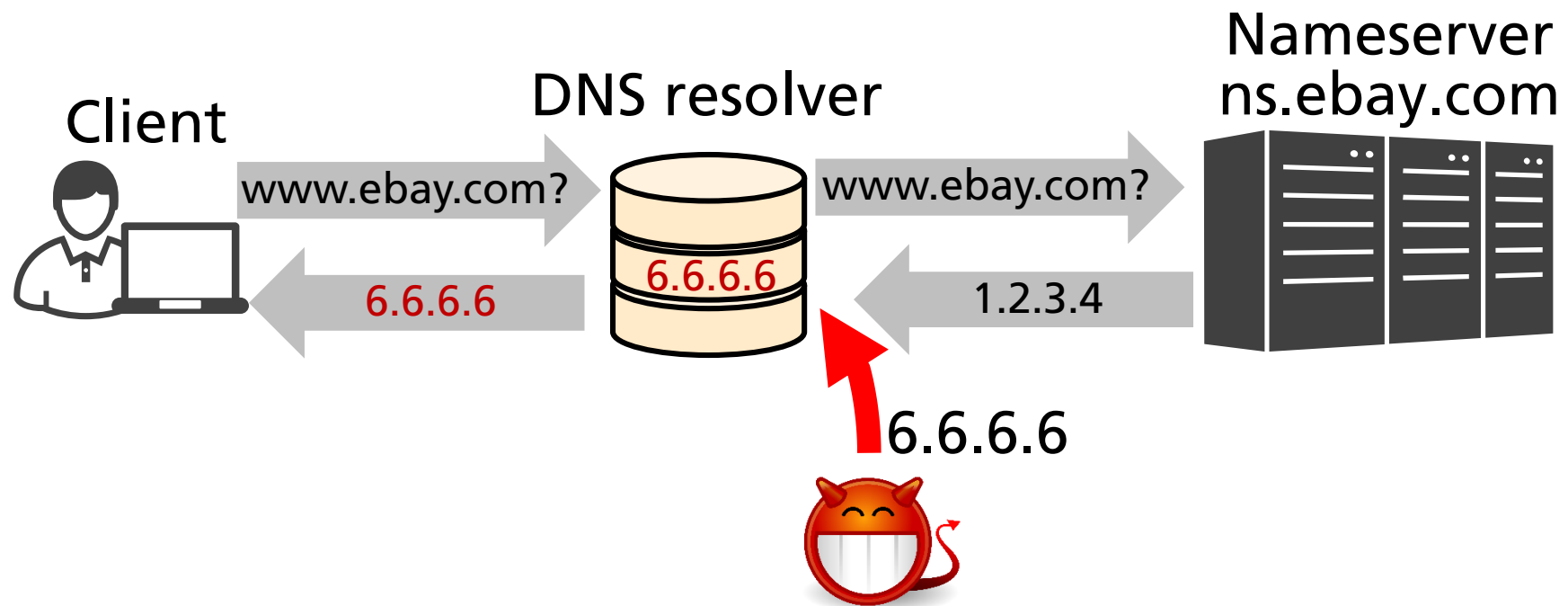

DNS – CHALLENGE RESPONSE SECURITY

- Prevention mechanisms against off-path attacks

- UDP source port randomization
- TXID randomization
- 32 random bits

- Here: impractical to guess

- Do fragmentation attack instead

Offsets	Octet	0				1				2				3																			
Octet	Bit	0	1	2	3	4	5	6	7	8	9	10	11	12	13	14	15	16	17	18	19	20	21	22	23	24	25	26	27	28	29	30	31
0	0	v4			IHL = 20				TOS				Total Length = 56																				
4	32	IPID								x		DF MF		Frag Offset																			
8	64	TTL				Protocol = 17				IP Header Checksum																							
12	96	Source IP = 7.7.7.7																															
16	128	Destination IP = 2.2.2.2																															
20	160	Source Port = 12345								Destination Port = 53																							
24	192	Length = 56								UDP Checksum = 0																							
28	224	TXID = 76543								QR	Opcode		AA	TC	RD	RA	Z	RCODE															
32	256	Question Count								Answer Record Count																							
36	288	Authority Record Count								Additional Record Count																							
40	320	Question Section																															
		Answer Section																															
		Authority Section																															
		Additional Section																															

IP FRAGMENTATION

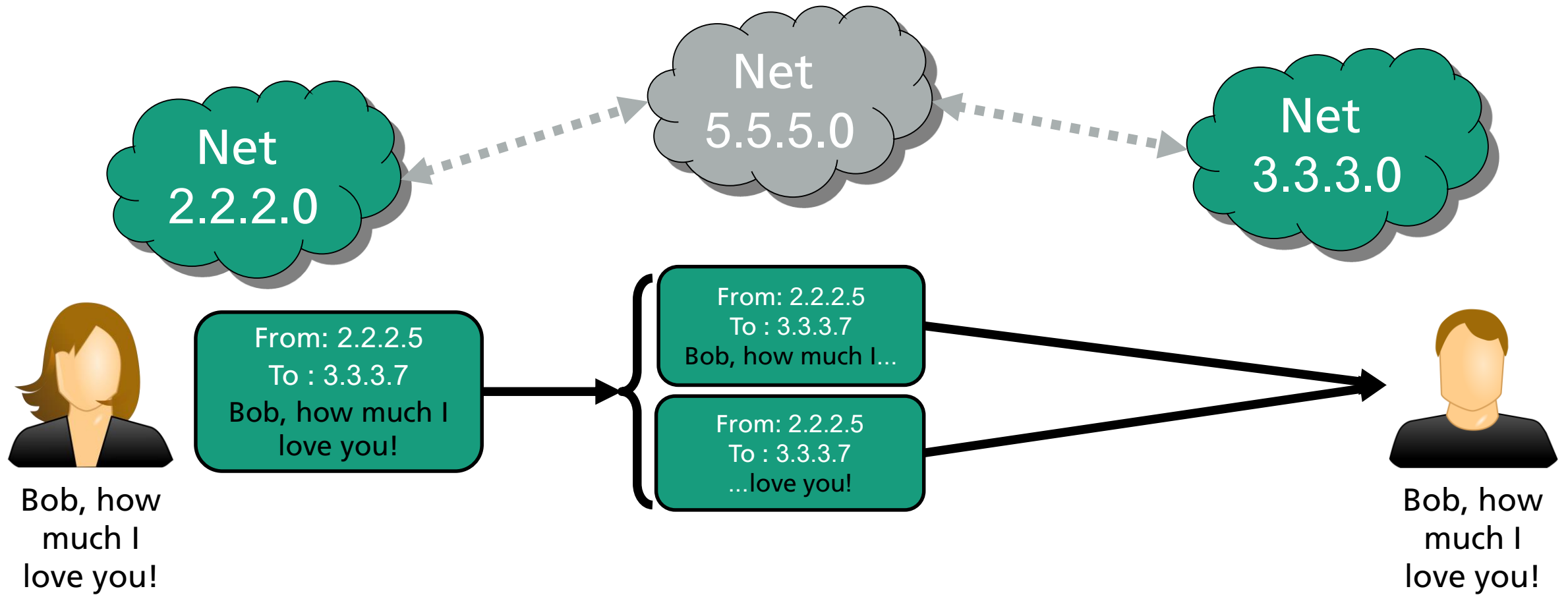

IP DEFRAGMENTATION CACHE POISONING

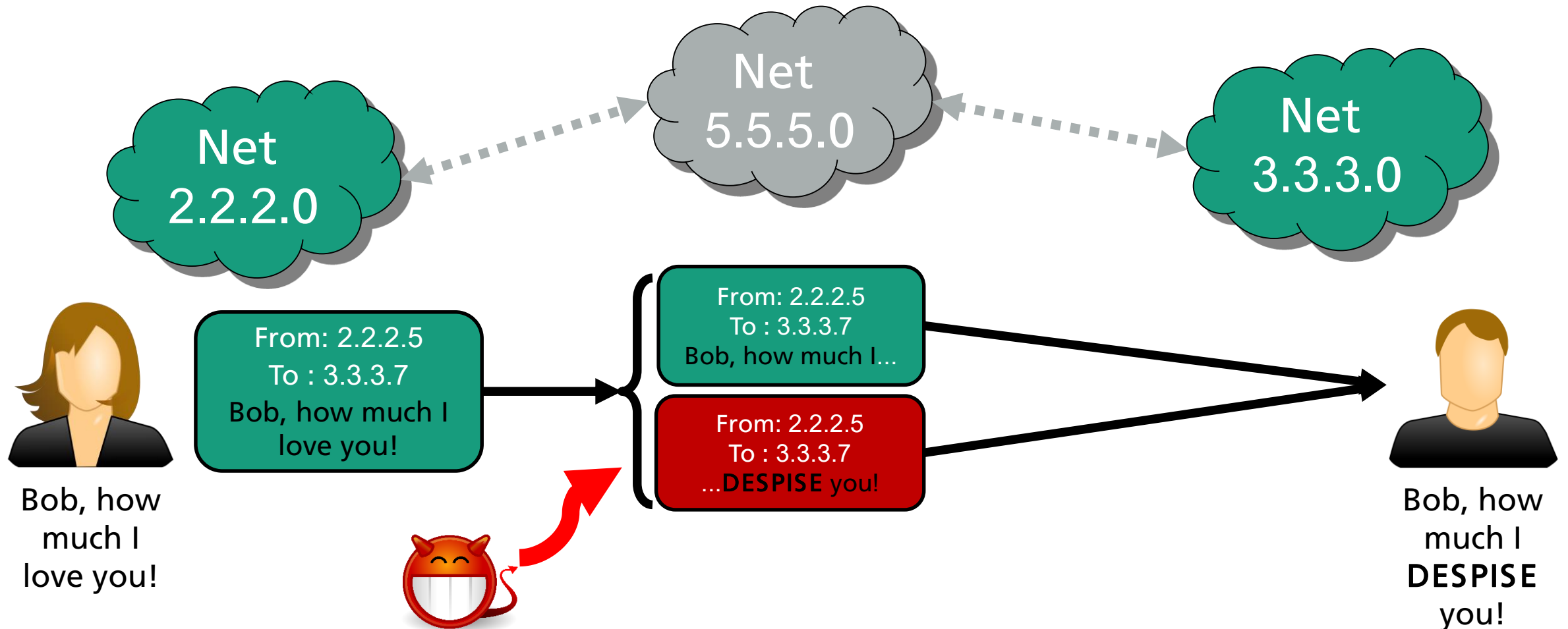

BYPASSING DNS OFF-PATH SECURITY MECHANISMS

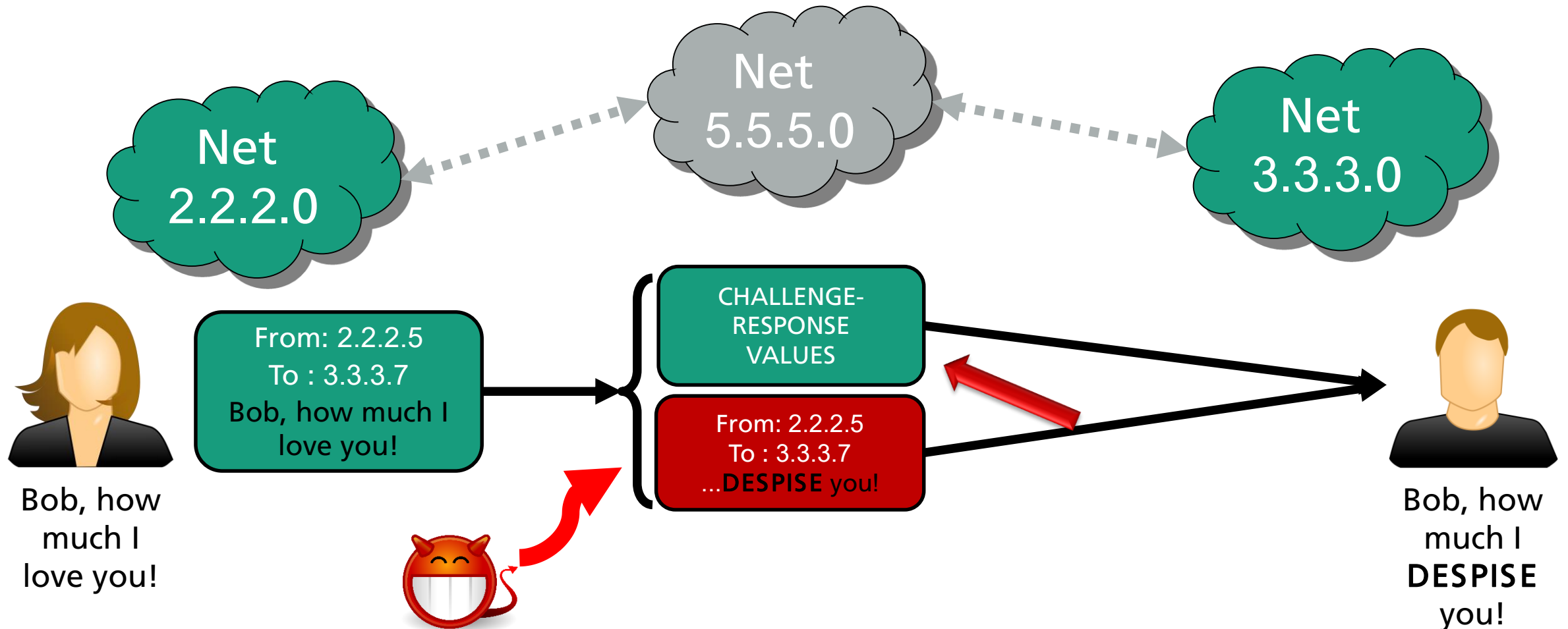

BYPASSING DNS OFF-PATH SECURITY MECHANISMS

FIRST FRAGMENT OF RESPONSE

Offsets	Octet	0								1								2								3									
Octet	Bit	0	1	2	3	4	5	6	7	8	9	10	11	12	13	14	15	16	17	18	19	20	21	22	23	24	25	26	27	28	29	30	31		
0	0	v4				IHL = 20				TOS								Total Length = 85																	
4	32	IPID = 23456																x	DF	MF	Frag Offset = 0														
8	64	TTL								Protocol = 17								IP Header Checksum																	
12	96	Source IP = 2.2.2.2																																	
16	128	Destination IP = 7.7.7.7																																	
20	160	Source Port = 53																Destination Port = 12345																	
24	192	Length = 65																UDP Checksum = 0x14de																	
28	224	TXID = 76543																QR	Opcode = 0				AA	TC	RD	RA	Z	RCODE = 0							
32	256	Question Count = 1																Answer Record Count = 1																	
36	288	Authority Record Count = 0																Additional Record Count = 1																	
40	320	4								m								a								i									
44	352	l								4								v								i									
48	384	c								t								2								i									
52	416	m								0								Type = A																	
56	448	Class = IN																Name (Pointer)																	
60	480	Type = A																Class = IN																	
64	512	TTL																																	

- Contains response to the challenge
- and parts of the DNS response
- Challenges
 - Guessing IPID
 - Matching UDP checksum

BYPASSING DNS OFF-PATH SECURITY MECHANISMS

SECOND FRAGMENT OF RESPONSE

DNS payload

Offsets	Octet	0							1							2							3													
Octet	Bit	0	1	2	3	4	5	6	7	8	9	10	11	12	13	14	15	16	17	18	19	20	21	22	23	24	25	26	27	28	29	30	31			
0	0	v4			IHL = 20				TOS							Total Length = 85																				
4	32	IPID = 23456															x	DF	MF	Frag Offset = 48																
8	64	TTL							Protocol = 17							IP Header Checksum																				
12	96	Source IP = 2.2.2.2																																		
16	128	Destination IP = 7.7.7.7																																		
20	160	Data Length = 4														IPv4 Address																				
24	192	= 2.2.2.2														Name = 0							Type													
28	224	= OPT							UDP Payload Size = 4096														EXTENDED-RCODE = 0													
32	256	Version = 0							DO	Z														Data Length												
36	288	= 0																																		

IP Header

Answer Section

Additional Section

➤ UDP checksum can be matched using true fragment

➤ IPID usually is guessable counter

CAUSING FRAGMENTATION WITH ICMP

Offsets	Octet	0				1				2				3																			
Octet	Bit	0	1	2	3	4	5	6	7	8	9	10	11	12	13	14	15	16	17	18	19	20	21	22	23	24	25	26	27	28	29	30	31
0	0	v4		IHL = 20				TOS				Total Length = 56																					
4	32	IPID								x DF MF		Frag Offset																					
8	64	TTL				Protocol = 1				IP Header Checksum																							
12	96	Source IP = 6.6.6.6																															
16	128	Destination IP = 2.2.2.2																															
20	160	Type = 3				Code = 4				ICMP Checksum																							
24	192	Unused								MTU = 100																							
28	224	v4		IHL = 20				TOS				Total Length = 76																					
32	256	IPID								x DF MF		Frag Offset																					
36	288	TTL				Protocol = 17				IP Header Checksum																							
40	320	Source IP = 2.2.2.2																															
44	352	Destination IP = 7.7.7.7																															
48	384	Source Port = 53								Destination Port = 12345																							
52	416	Length = 56								UDP Checksum = 0																							



- Type=3
 - "Destination unreachable"
- Code=4
 - "Fragmentation needed and DF set"

AGENDA

- Objectives
- Attacking
- Impact
- Mitigation
- Summary

ATTACKER ISSUES FRAUDULENT CERTIFICATE

Attacker: attacker.info
@199.244.49.220

Certificate Authority Web Server Email Server Resolver

Victim: victim-org.info
@198.22.162.189

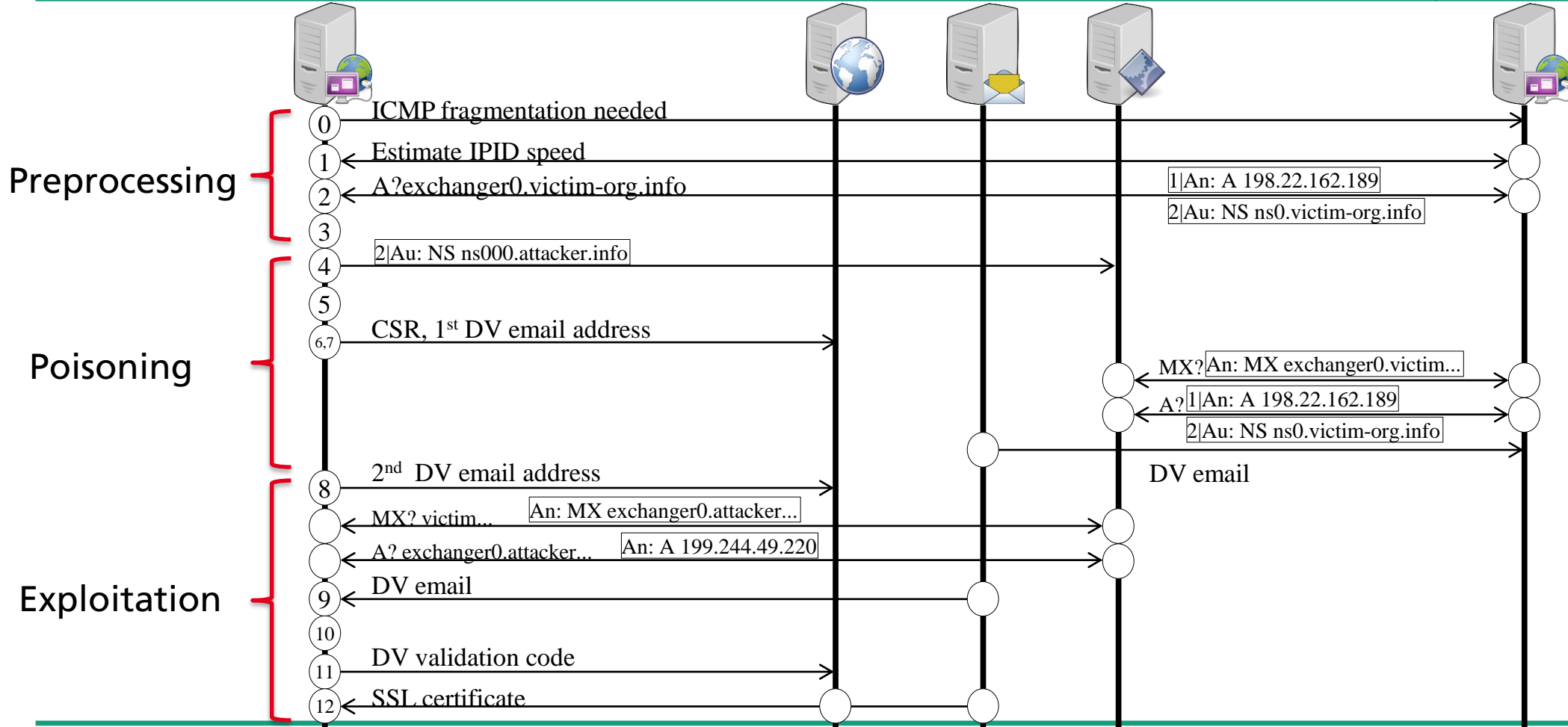

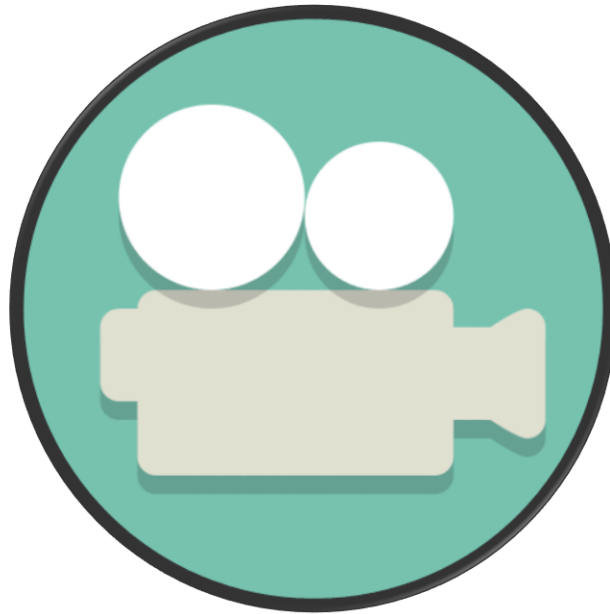

USING IT

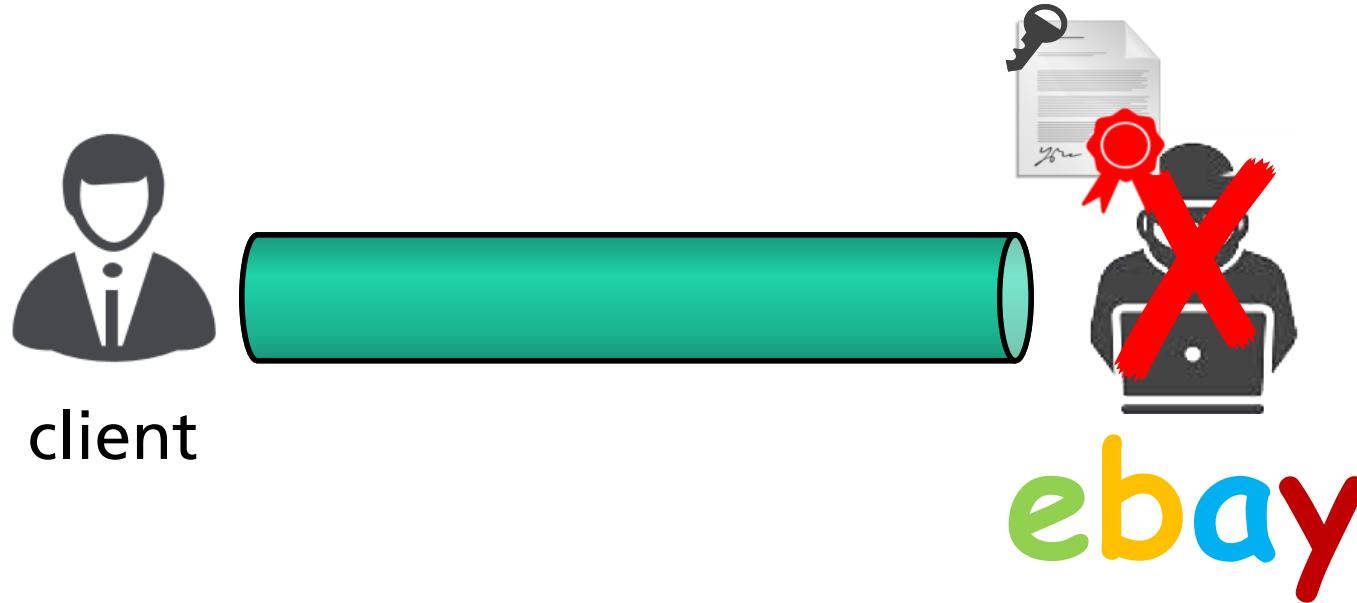

Our certificate is signed by a trusted CA.

AGENDA

- Objectives
- Attacking
- Impact
- Mitigation
- Summary

EFFECTS ON VICTIMS

- For victim users
 - Injected malware
 - Theft of credentials, sensitive data, identity, ...

- Loss of reputation and trust
 - For victim CA
 - and target domain

VULNERABILITIES IN THE WILD

- We tested 17 CAs that perform Domain Validation
 - Covering > 95% of the certificate market
 - Found 5 vulnerable
 - Only one vulnerable CA is sufficient to obtain the target certificate
 - Usually it does not matter, which CA signed it
- Web PKI security is undermined
-

AGENDA

- Objectives
- Attacking
- Impact
- Mitigation
- Summary

PRECONDITIONS FOR THE ATTACK

- Domain Validation
 - Is offered in the first place

- IP fragmentation allowed
 - for victim name server of target domain
 - in CA network

- DNS via UDP

MITIGATION TECHNIQUES

- Disable Domain Validation?
 - Would leave us only with much more expensive alternatives

 - Suppress IP Fragmentation?
 - Would disconnect some networks

 - Force DNS over TCP?
 - Off-path TCP injection attacks do exist
 - Also: Short-lived BGP prefix hijacks for MITM DNS cache poisoning are on the rise
-

MITIGATION TECHNIQUES

➤ We need MITM resilient Domain Validation

■ DoH / DoT?

- Securing a PKI with the very same PKI?

■ DNSSEC?

- The way to go
- But still not properly deployed since mid-90s!

DROP-IN REPLACEMENT DOMAIN VALIDATION++

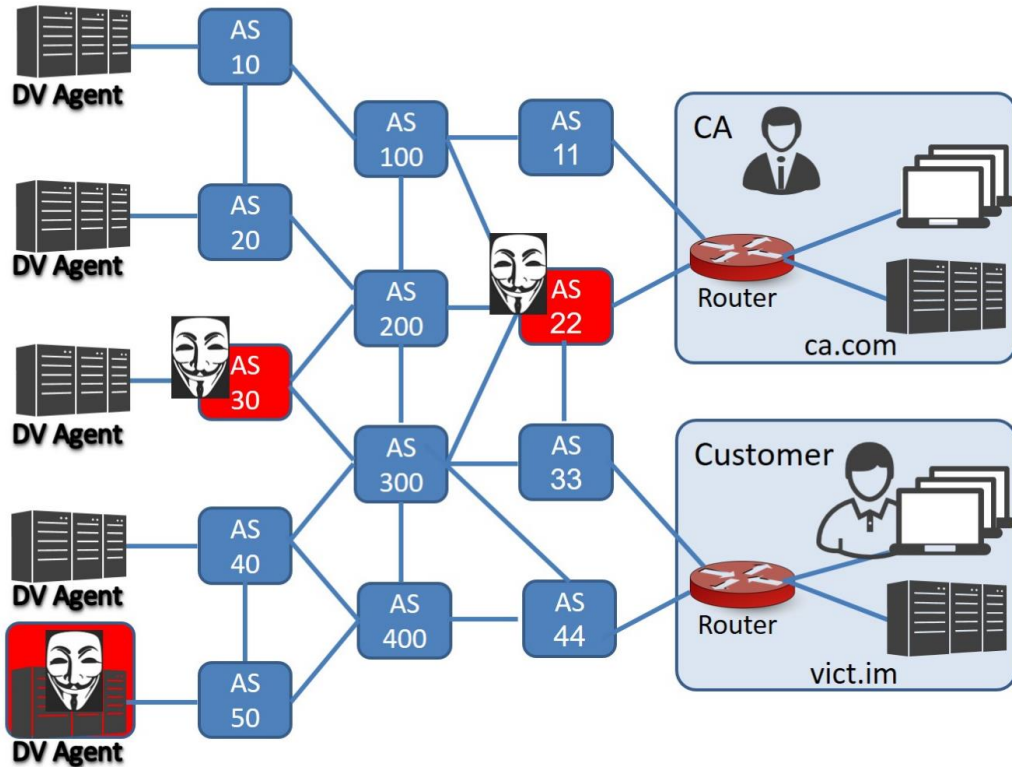

- Uses orchestrator that evaluates voting from hardened DV agents
 - each performing the DNS part
- Communicates via HTTPS
 - Using out-of-pki certificates
- Over (mostly) non-overlapping paths through the internet

➤ For more details, visit pki.cad.sit.fraunhofer.de

AGENDA

- Objectives
- Attacking
- Impact
- Mitigation
- Summary

SUMMARY

- Off-path attack against Domain Validation
- Using DNS cache poisoning and IP defragmentation cache poisoning
- To acquire fraudulent certificates for domains under foreign operation
- Web PKI, which is meant to provide security against strong MITM attackers, relies on a weak building block that can be circumvented even by a weak off-path attacker.

FURTHER INFORMATION

pki.cad.sit.fraunhofer.de